

SERVICE GUIDE

A-DEC® SIMULATORS

Mobile (4810) and Stationary (4820)

A-DEC[®] MOBILE AND STATIONARY SIMULATORS
4810 AND 4820
SERVICE GUIDE

Copyright

© 2015 A-dec[®] Inc. All rights reserved.
2601 Crestview Drive, Newberg, OR 97132, USA
Printed in USA.

A-dec Inc. makes no warranty of any kind with regard to this material, including, but not limited to, the implied warranties of merchantability and fitness for a particular purpose. A-dec, Inc. shall not be held liable for any errors contained herein or any consequential or other damages concerning the furnishing, performance or use of this material. The information in this document is subject to change without notice. If you find any problems in the documentation, please report them to us in writing. A-dec Inc. does not warrant that this document is error-free.

No part of this document may be copied, reproduced, altered, or transmitted in any form or by any means, electronic or mechanical, including photocopying, recording, or by any information storage and retrieval system, without prior written permission from A-dec Inc.

Publication Number: 85.0814.00

Revision Date: Rev E 7-2015

Trademarks

A-dec, the A-dec logo, A-dec 500, Cascade, Cascade Master Series, Century Plus, Continental, Decade, ICX, Performer, Preference, Preference Collection, Preference ICC, and Radius are registered trademarks in the U.S. Patent and Trademarks office.

Preference Slimline and ICV are also trademarks of A-dec Inc.

Comments and Feedback

Thank you for taking the time to use this manual. We would appreciate any feedback or comments you have about this document. Please mail, e-mail, or phone us with your comments. You can reach us at:

A-dec Inc.
Technical Communications Department
2601 Crestview Drive
Newberg, OR 97132

Reach us by phone at: 1.800.547.1883
E-mail: techcomm@a-dec.com
website: www.a-dec.com

CONTENTS

CHAPTER 1: INTRODUCTION

Inside This Guide	2
Document Conventions	2
Getting Support.....	3
Customer Service	3
Serial and Model Numbers.....	4
Mobile and Stationary Simulators	4
Mobile Simulator Lights	5
Stationary Simulator Lights.....	6
Reading Serial Number Labels	7
Service Tools	8
Recommended Tools	8

CHAPTER 2: A-DEC MOBILE SIMULATOR

Flow Diagrams.....	12
Mobile Simulator, Self-contained Water, Standard Control Block ...	13
Mobile Simulator, City Water, Standard Control Block	14
Mobile Simulator, Self-contained Water, Century Plus Block	15
Mobile Simulator, City Water, Century Plus Control Block.....	16

Illustrated Parts Breakdown	17
Mobile Simulator Utilities - Simulator Mounted	18
Mobile Simulator Utilities - Bench Mounted	20
Mobile Simulator Vacuum Generator and Muffler Tray	23
Mobile Simulator Lift Cylinder and Casters	24

CHAPTER 3: A-DEC STATIONARY SIMULATOR

Flow Diagrams	28
Stationary Simulator, Self-contained Water, Standard Block	29
Stationary Simulator, City Water, Standard Control Block	30
Stationary Simulator, Self-contained Water, Century Plus Block ...	31
Stationary Simulator, City Water, Century Plus Control Block	32
Illustrated Parts Breakdown	33
Stationary Simulator Vacuum Generator and Muffler Tray.....	34
Writing Surface	36
Monitor Mount	37

CHAPTER 4: CROSS-SYSTEM FEATURES

Overview	41
A-dec Tubing	41
Handpiece Tubing	44

Manikins 45

Flow Diagrams 46

 Intraoral Light, Standard Control Block 47

 Intraoral Light, Century Plus Control Block 48

 EA-40LT Electric Micromotor 49

Service/Usage 50

 Accessing the Carriage Assembly 50

 Using the EA-40LT Electric Micromotor 51

Adjustments and Maintenance 52

 Making Handpiece Adjustments 53

 Making Syringe Adjustments, Standard Control Block 55

 Making Syringe Adjustments, Century Plus Control Block 55

 Adjusting the A-dec Dual Voltage Intraoral Light Source 56

 Adjusting the Torso Brake (Rotation) 57

 Adjusting the Headrest and Back Assembly 58

Illustrated Parts Breakdown 59

 Carriage Assembly, Standard Control Block 60

 Carriage Assembly, Century Plus Control Block 61

 Standard Simulator Control Block Assembly, Two Handpiece 62

 Century Plus Simulator Control Block 63

 Century Plus Simulator Control Block Manifold 64

 Master Toggle – Century Plus Control Block Only 65

 Handpiece Selector Valve, Two Handpiece 66

 Handpiece Selector Valve, Three Handpiece 67

 Foot Control Wet/Dry Toggle Valve 68

 Foot Control Valve Assembly 69

 Autoclavable Syringe 70

 Autoclavable HVE Standard Assembly, Central Vacuum 71

 Simulator Vacuum Generator Assembly 72

 AVS Valve Assembly 73

 Vacuum Canister/AVS Lid 74

 Torso Brake Parts 76

 Air Filter/Regulator and Water Filter/Regulator 78

 Air-actuated Water Shutoff Valve 80

 Button Valve 82

 Handpiece Holder Arms 84

 Tray Holder 85

 Headrest and Back Assembly 86

Third Hand Kit 88

17 Watt Power Supply 91

25 Watt Power Supply 92

300 Watt Power Supply 94

CHAPTER 5: TROUBLESHOOTING

Troubleshooting the Carriage Assembly 98

Troubleshooting the Standard Simulator Control Block ... 100

Troubleshooting the Century Plus Control Block 101

Troubleshooting the Foot Control 110

Troubleshooting the Autoclavable Syringe 113

Troubleshooting the HVE Valve, Central Vacuum 114

Troubleshooting the Air Vacuum System (AVS) 115

Troubleshooting the Torso Brake 118

Troubleshooting the Mobile Lift Cylinders and Casters.... 120

CHAPTER 6: DENTAL LIGHTS

Adjustments and Maintenance 122

 6300 Dental Light Adjustments 123

 6300 Light Head Rotation 123

 Performer Dental Light Adjustments 125

 Flexarm Adjustments for 6300 and Performer Lights 127

 Maintaining the 6300 and Performer Dental Light 128

 6300 Dental Light Lamp Replacement 129

 Performer Dental Light Lamp Replacement 130

Illustrated Parts Breakdown 131

 6300 Light Head 132

 Performer Light Head 133

Troubleshooting the Dental Light 134

INDEX 135



INTRODUCTION

Welcome to the *A-dec Simulator Service Guide*. This guide provides a complete review of the A-dec Mobile Simulator, A-dec Stationary Simulator, dental lighting, and cross-system features, including manikin options.

This guide is intended for newly trained and seasoned service technicians responsible for installing and maintaining A-dec simulators. The technician should understand the operation of dental equipment, how to use flow diagrams, and how to perform basic maintenance on dental or medical equipment.

INTRODUCTION CONTENTS

- Inside This Guide, page 2
- Document Conventions, page 2
- Customer Service, page 3
- Serial and Model Numbers, page 4
- Service Tools, page 8

Figure 1 A-dec Simulators

A-dec Stationary Simulator Model 4820

(Shown with optional A-dec 6300 Dental Light and Writing Surface)

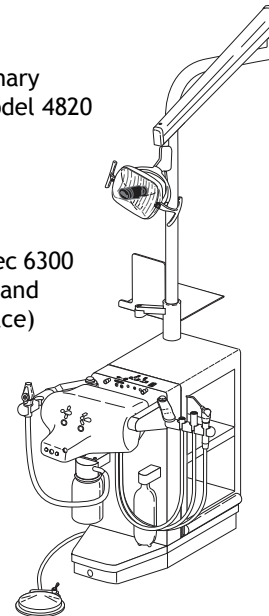

A-dec Mobile Simulator Model 4810

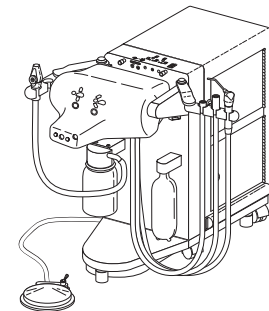

Inside This Guide

Inside this guide you will find the tools, maintenance, adjustments and troubleshooting information for servicing A-dec Simulators and options.

This guide contains:

- Adjustments and maintenance information
- Flow diagrams for routing and wiring
- Step-by-step instructions for troubleshooting
- Part number information on serviceable parts
- Exploded illustrated parts breakdown of assemblies, showing sequence of assembly

Document Conventions

A number of items and instructions appear throughout this document. The information contained within these pages uses special formatting, note styles and symbols to help identify important instructions or component status.

Formatting Conventions

The formatting conventions are designed to make information quick and easy to find and understand.

- *Italic* type is used to indicate document names and show emphasis.
- **Bold** type indicates new terms or glossary terms, and is used for section headings



WARNING Warnings indicate potential loss of life or limb.



CAUTION Cautions indicate potential equipment damage.



NOTE Notes indicate additional information.

Part Identification Symbols

The conventions for the serviceable components tables are designed to identify all parts and kits, including ones that are not for sale. Symbols with reference notes are used.

Symbol	Definition
†	Indicates that the individual part is not available for sale. (These parts are typically part of a kit or larger assembly that is for sale.)
*	The part belongs to a kit.
No symbol	Part is for sale.

GETTING SUPPORT

Customer Service

For questions not addressed in this document, contact A-dec Customer Service using contact information for your region.

A-dec Schools Customer Service

2601 Crestview Drive
P.O. Box 111
Newberg, Oregon 97132
Telephone: 1 (800) 547-1883
Fax: (503) 537-2702
Internet: www.a-dec.com
E-mail: schools@a-dec.com

International Customer Service

2601 Crestview Drive
Newberg, Oregon 97132
Telephone: 1 (503) 538-9471 or 1 (503) 538-7478
Fax: (503) 538-5911
Internet: www.a-dec.com

For a complete list of all A-dec authorized service parts, refer to the *A-dec Service Guide* (p/n 85.0812.00) and the *A-dec Service Parts* catalog (p/n 85.5000.00).

Serial and Model Numbers

Product serial and model number information can be found on the serial/model number labels. When you contact customer service, the serial number helps identify the product and when it was manufactured.

Mobile and Stationary Simulators

Table 1 lists the model numbers for the Mobile and Stationary Simulators. Figure 2 shows the serial/model number label location for the simulators.

Table 1 Mobile and Stationary Simulator Model Numbers

Model Number	Description
Model 4810	Mobile Simulator
Model 4820	Stationary Simulator

Figure 2 Serial/Model Number Location for Simulators (Mobile Unit Shown)

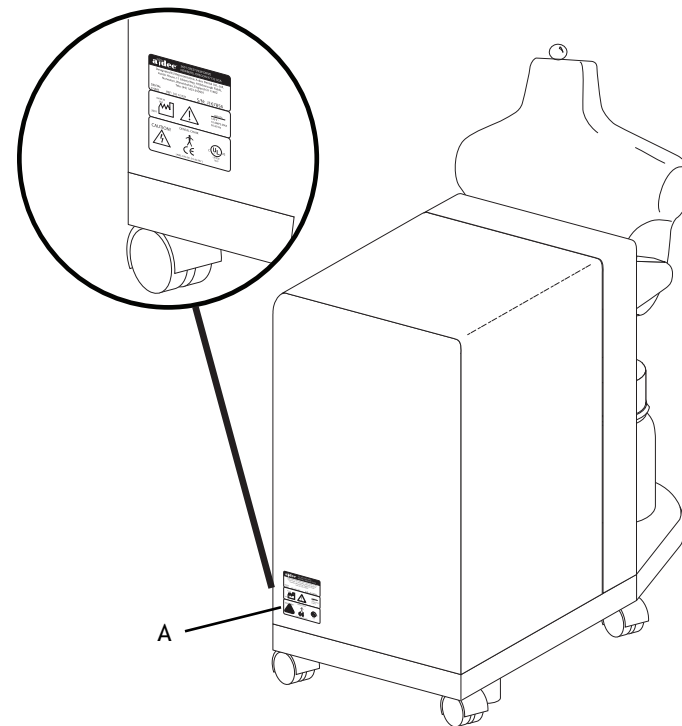

(A) Unit Serial/Model label location

Mobile Simulator Lights

Table 2 lists the part numbers for the Mobile Simulator lights. Figure 3 and Figure 4 show the serial/model number label locations.

Table 2 Mobile Simulator Light Part Numbers

Part Number	Description
83.0499.00	In-bench Light, 120V
83.0425.00	Universal Lab Light, single, 120V
83.0370.00	Universal Lab Light, dual, 120V
83.0383.00	Universal Lab Light, single, 240V
83.0386.00	Universal Lab Light, dual, 240V

Figure 3 Serial/Model Number Location for the Universal Lab Light

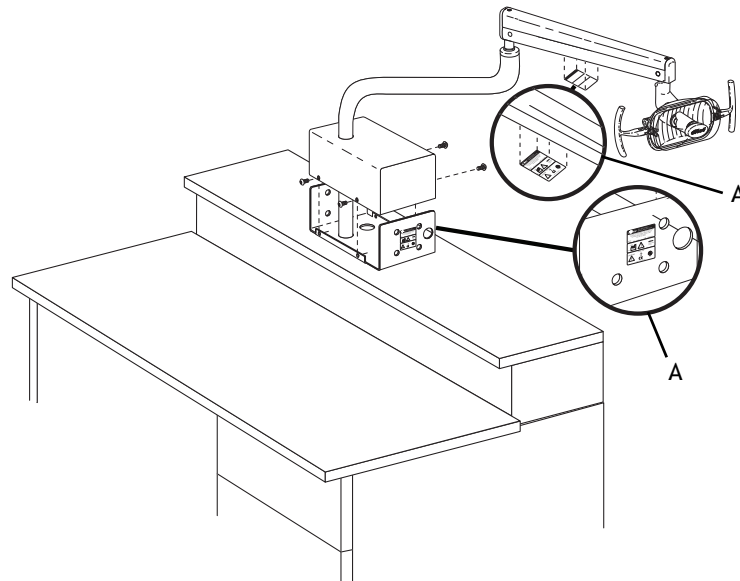

(A) Serial/Model Label Locations (label may be in either location)

Figure 4 Serial/Model Number Location for the In-bench Light

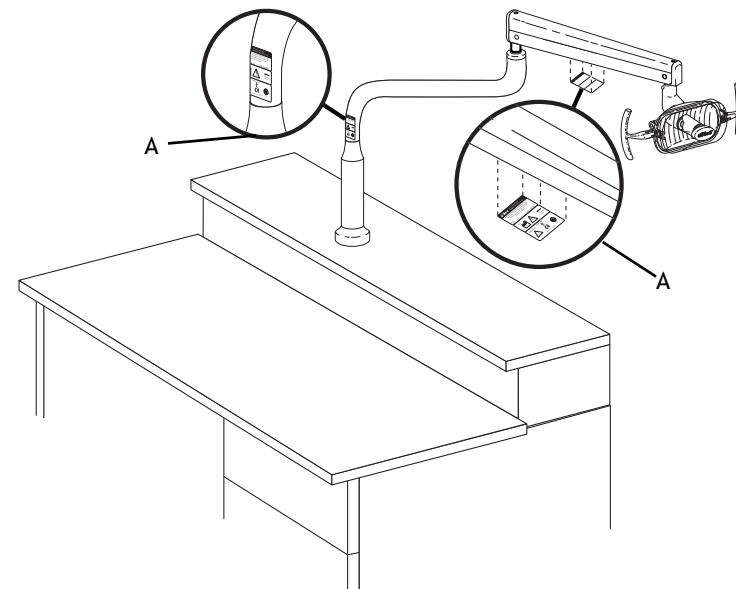

(A) Serial/Model Label Location (label may be in either location)

Stationary Simulator Lights

Table 3 lists the part numbers for the Stationary Simulator lights. Figure 5 shows the serial/ model number label locations.

Table 3 Stationary Simulator Light Part Numbers

Part Number	Description
83.0120.00	A-dec 6300 Dental Light
83.0121.00	A-dec 6300 Dental Light with call light
83.0355.00	Performer Light

Figure 5 Serial/Model Number Location for Stationary Simulator Light

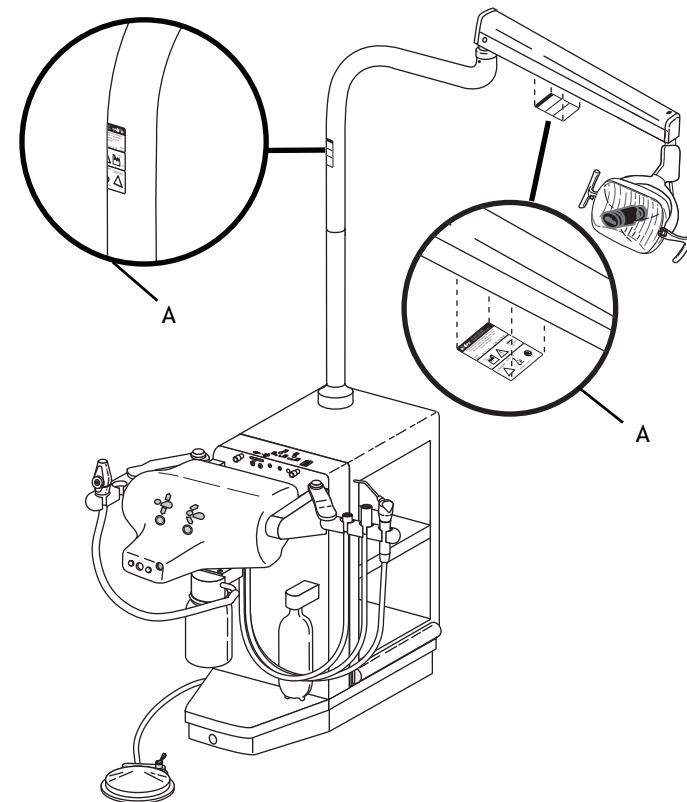

(A) Serial/Model Label Location

Reading Serial Number Labels

Use the tables below and Figure 6 to understand the serial/model number information on the label. The **REF:** number is the model number. The **S/N:** is the serial number. The first letter of the serial number is the month the product was manufactured (see Table 4). The first digit following the letter is the year the product was manufactured.

Table 4 Month Identification Table

Letter	Month	Letter	Month
A	January	G	July
B	February	H	August
C	March	I	September
D	April	J	October
E	May	K	November
F	June	L	December

Figure 6 Serial Number Label

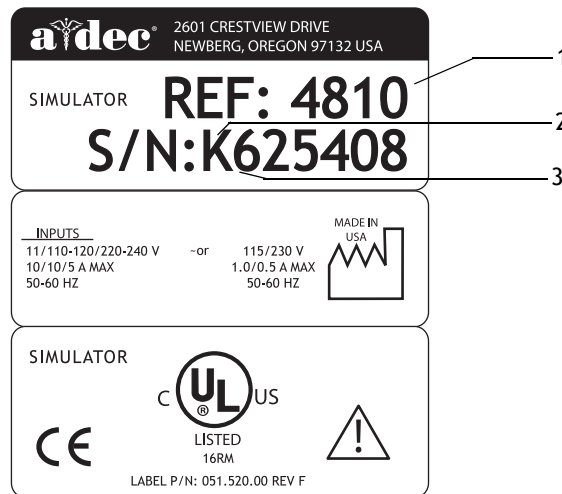

Table 5 Serial/Model Number Identification Table

Item	Description
1	Model number of the product
2	Month code (see Table 4)
3	Year the product was manufactured





Serial/model number identification using the Model 4810 label as an example



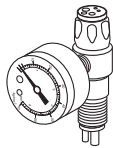

SERVICE TOOLS

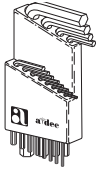
Recommended Tools

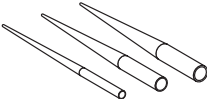
Table 6 lists the types of tools available from A-dec for servicing A-dec equipment and their recommended use.

Table 6 Recommended Tools

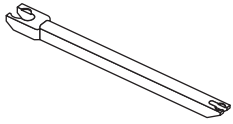
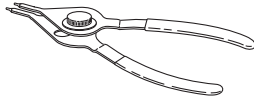
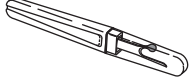
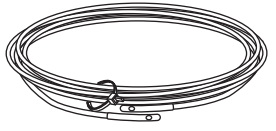
Tool	Task	Part Illustration	Part Number
Drive air pressure gauge	Adjusts handpiece drive air pressure, 0-60 psi (4.13 bar). This gauge does not fit the Borden 3-hole coupler		50.0271.00
Hemostat	Troubleshoots or repairs a unit to stop air or water flow through		009.008.00
Hex key set	Servicing or installs A-dec equipment (plastic case included)		009.018.00
Loctite	Secures threaded fasteners to prevent loosening		060.001.00 (Red 271) 060.002.00 (Blue 242)
O-ring tools	Replaces O-rings during quick field repairs (fits the four smallest O-ring sizes)		009.013.00

Tool	Task	Part Illustration	Part Number
Panel mount gauge	Checks air/water pressure Can also be used as an inline pressure gauge for testing purposes		026.118.00
Silicone lubricant	Lubricates internal moving parts such as O-rings, oral evacuator valves, and bushings		98.0090.01
Sleeve tool	Aids in securing 1/4" sleeves and 1/8" uni-clamps		98.0072.00
Snap ring tool	Installs and removes internal and external snap rings (fits all snap rings used in A-dec equipment)		009.007.00
stripper	Separates the extruded air and water lines in vinyl		009.035.00
Umbilical stringer	Routes additional or wiring through existing umbilical assemblies (12' [3.66 mm] stringer with threading holes on both ends)		009.015.00
Valve test syringe	Quickly tests pilot-operated valves; used to apply a static pressure of 5-75 psi (.34-5.17 bar)		98.0050.01

A-DEC MOBILE SIMULATOR

The A-dec Mobile Simulator Model 4810 provides a mobile training center for dental students and can be used with a variety of manikins (described on page 45). This chapter includes Mobile Simulator flow diagrams and illustrated parts breakdowns.

Figure 7 A-dec Mobile Simulator Model 4810

MOBILE SIMULATOR CONTENTS

- Flow Diagrams, page 12
- Illustrated Parts Breakdown, page 17

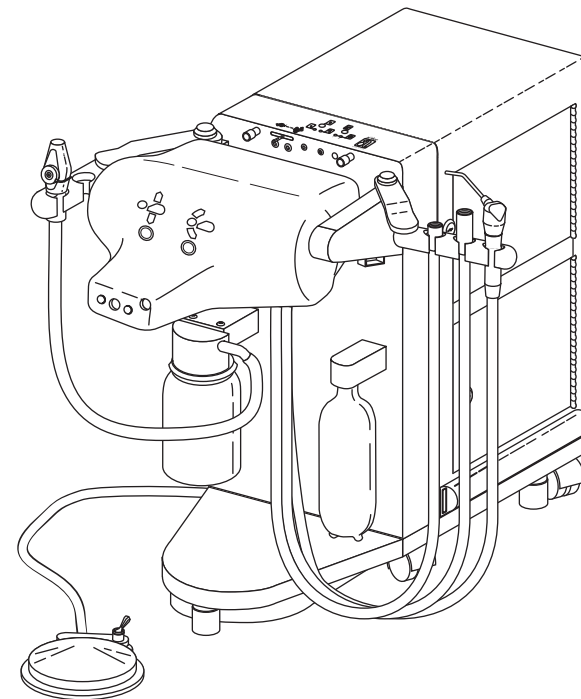

Flow Diagrams

The A-dec Mobile Simulator comes with or without the self-contained water system, with either an air vacuum system (AVS) or a central vacuum, and with either a standard control block or the Century Plus[®] control block. This section includes flow diagrams showing these configurations.

MOBILE SIMULATOR FLOW DIAGRAMS

- **Mobile Simulator, Self-contained Water, Standard Control Block, page 13**
- **Mobile Simulator, City Water, Standard Control Block, page 14**
- **Mobile Simulator, Self-contained Water, Century Plus Block, page 15**
- **Mobile Simulator, City Water, Century Plus Control Block, page 16**

Mobile Simulator, Self-contained Water, Standard Control Block

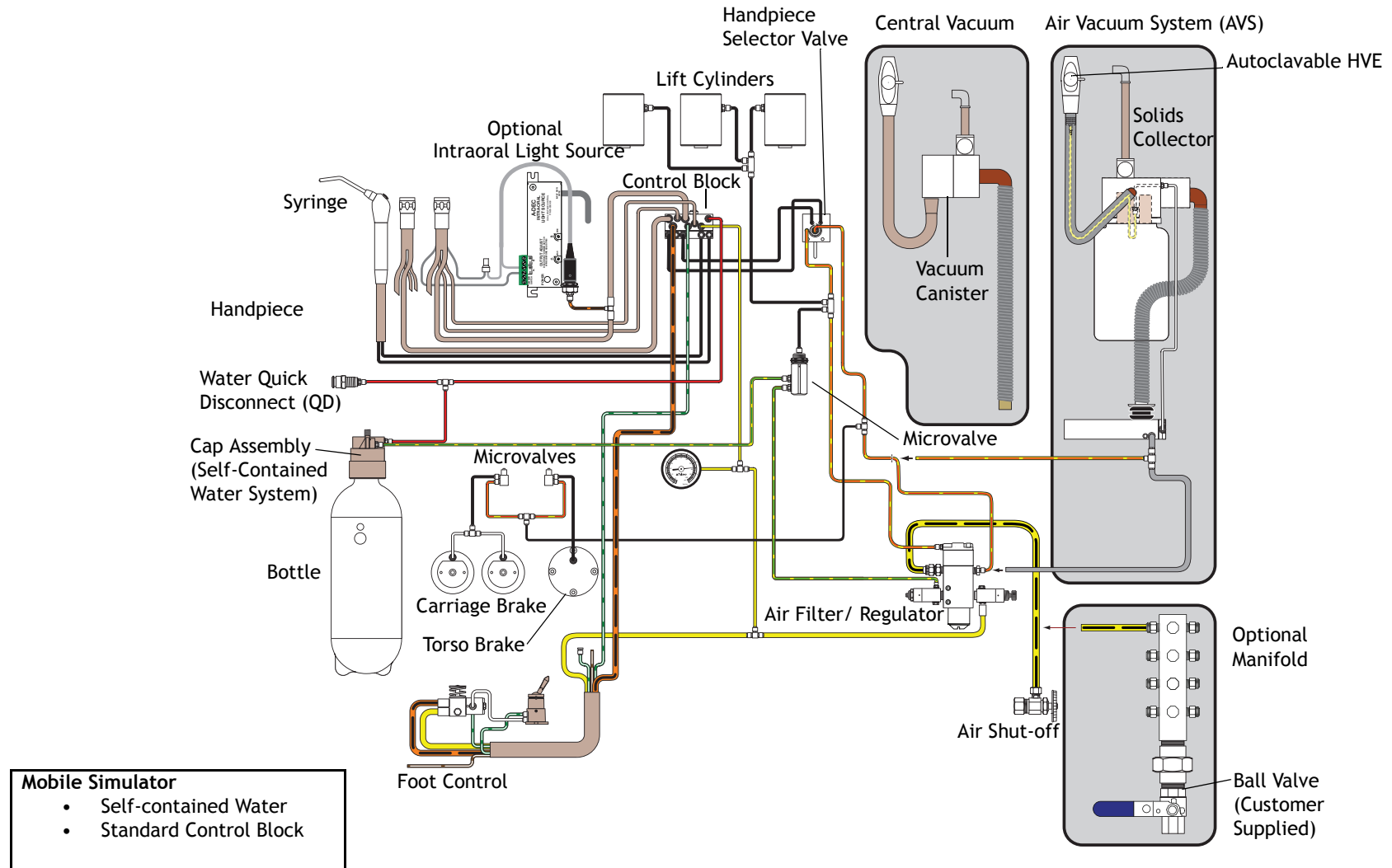

Mobile Simulator

Mobile Simulator, City Water, Standard Control Block

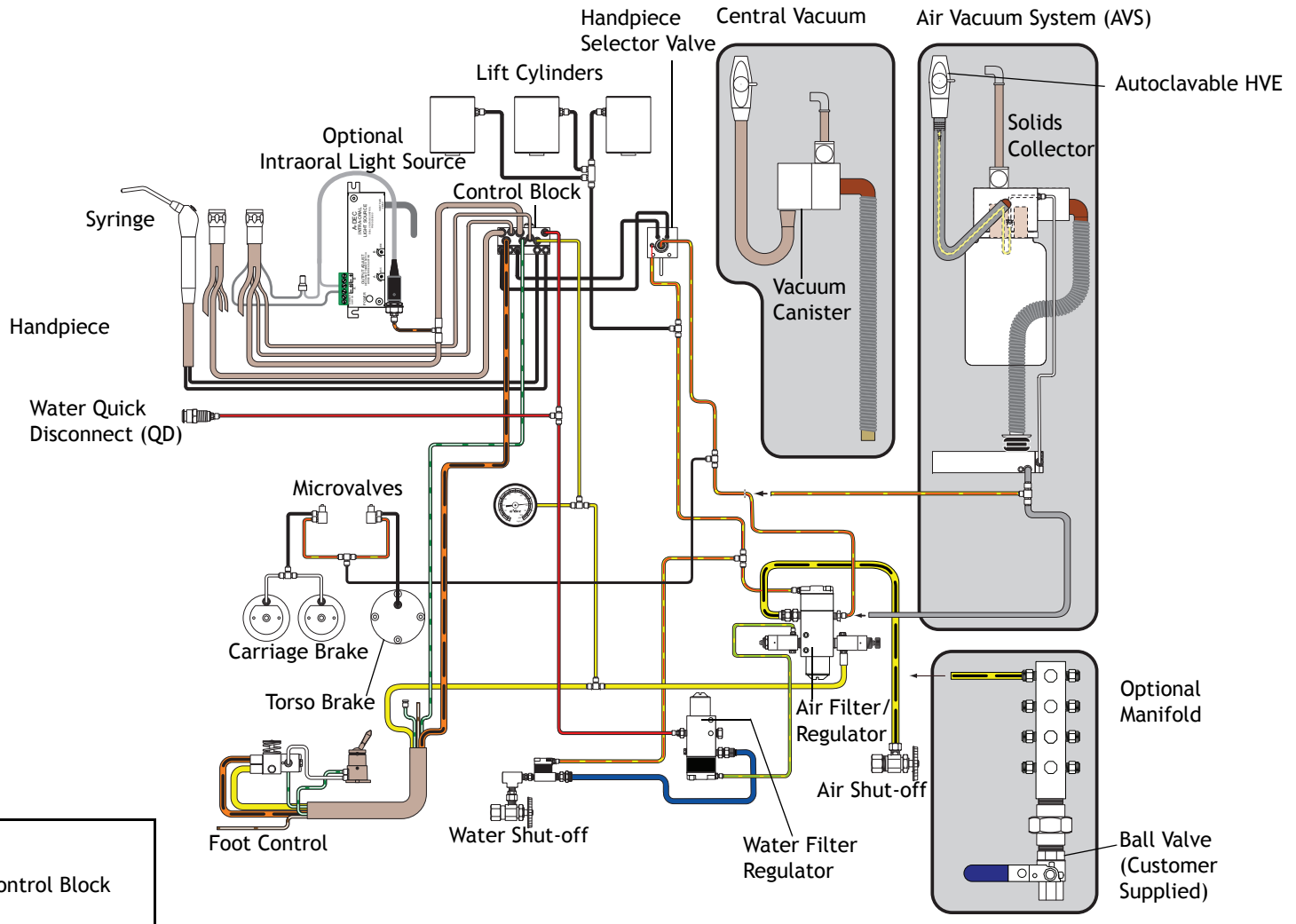

Mobile Simulator

- City Water
- Standard Control Block

Mobile Simulator, Self-contained Water, Century Plus Block

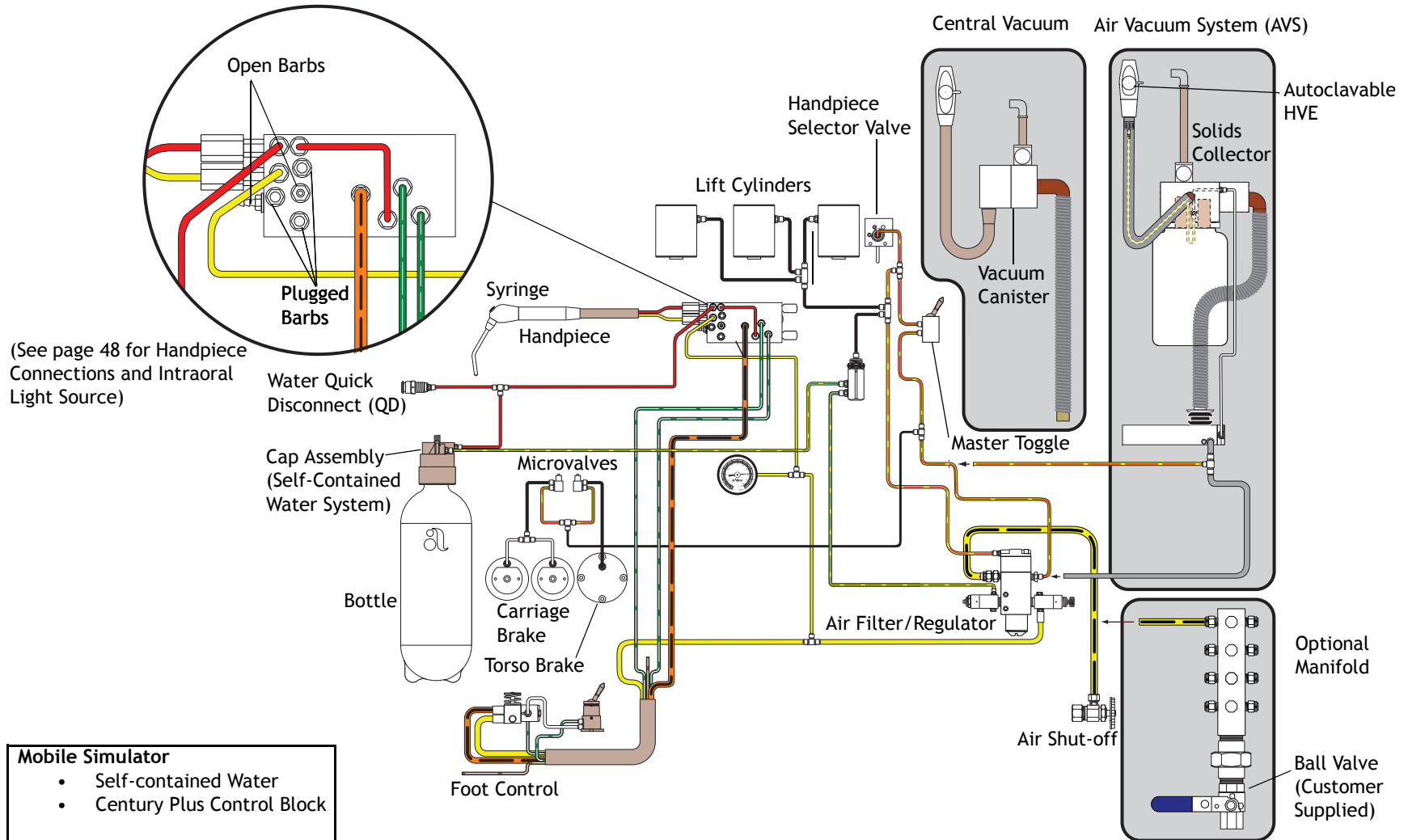

Mobile Simulator

Mobile Simulator, City Water, Century Plus Control Block

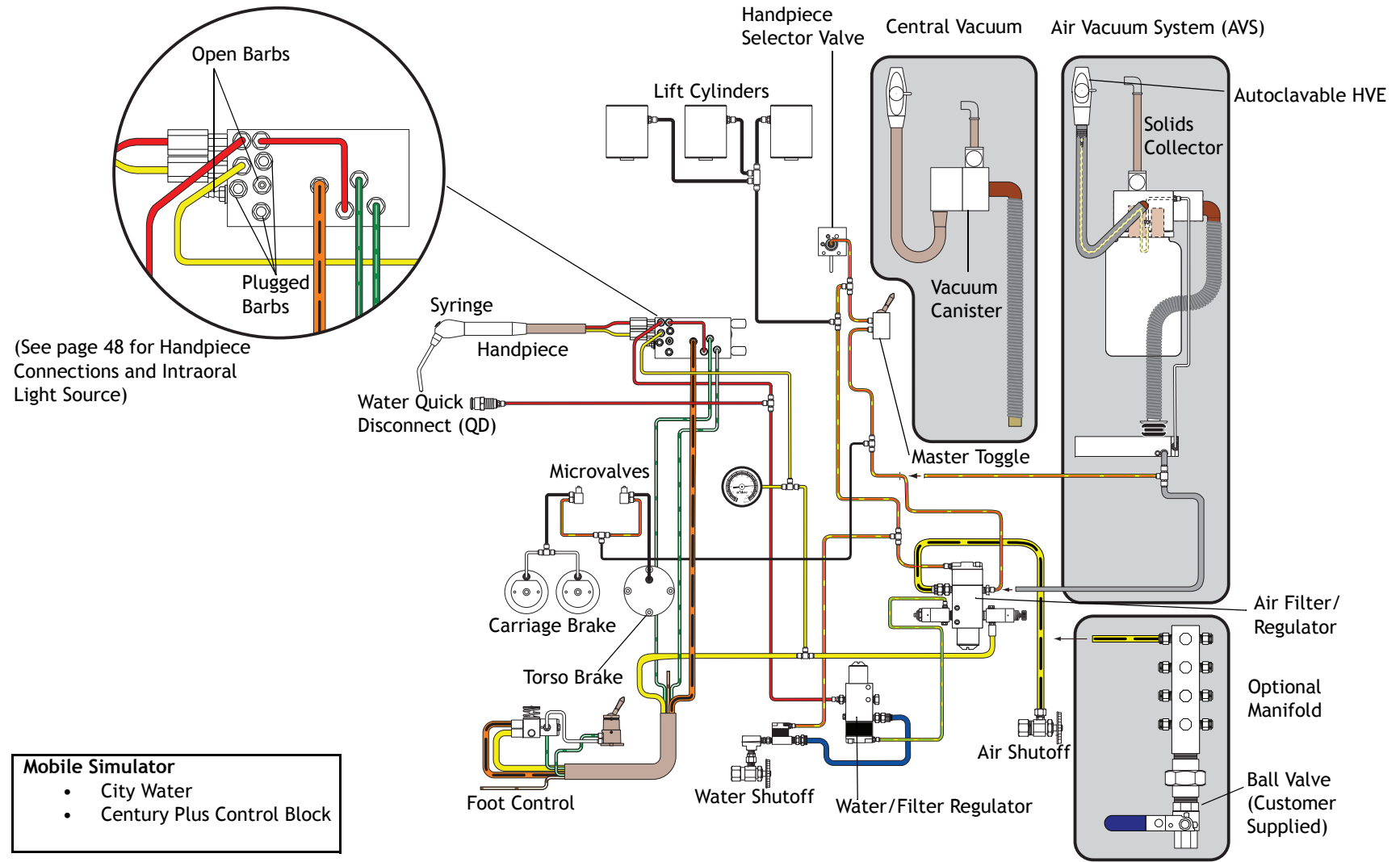

Illustrated Parts Breakdown

This section contains illustrated parts breakdowns for items related only to the A-dec Mobile Simulator Model 4810.

Part Identification Symbols

The conventions for the serviceable components tables are designed to identify all parts and kits, including ones that are not for sale. Symbols with reference notes are used.

Symbol	Definition
†	Indicates that the individual part is not available for sale. (These parts are typically part of a kit or larger assembly that is for sale.)
*	The part belongs to a kit.
No symbol	Part is for sale.

MOBILE SIMULATOR IPB CONTENTS

- Mobile Simulator Utilities - Simulator Mounted, page 18
- Mobile Simulator Utilities - Bench Mounted, page 20
- Mobile Simulator Vacuum Generator and Muffler Tray, page 23
- Mobile Simulator Lift Cylinder and Casters, page 24

Mobile Simulator Utilities - Simulator Mounted

Item	Part Number	Description
1	001.016.01	Socket head screw
2	001.103.00	Button head screw
3	004.229.00	Nylon washer
4	005.109.00	Button head screw
5	006.023.00	Nut
6	026.099.00	Horizontal gauge
7	83.0152.00	Umbilical assembly
8	83.0156.00	Lanyard assembly
9	83.0202.00	Utility center cover
10	83.0205.00	Air filter/regulator assembly
11	83.0210.00	Water filter/regulator assembly

Figure 8 Utilities with Air Filter/Regulator - Self-contained Water

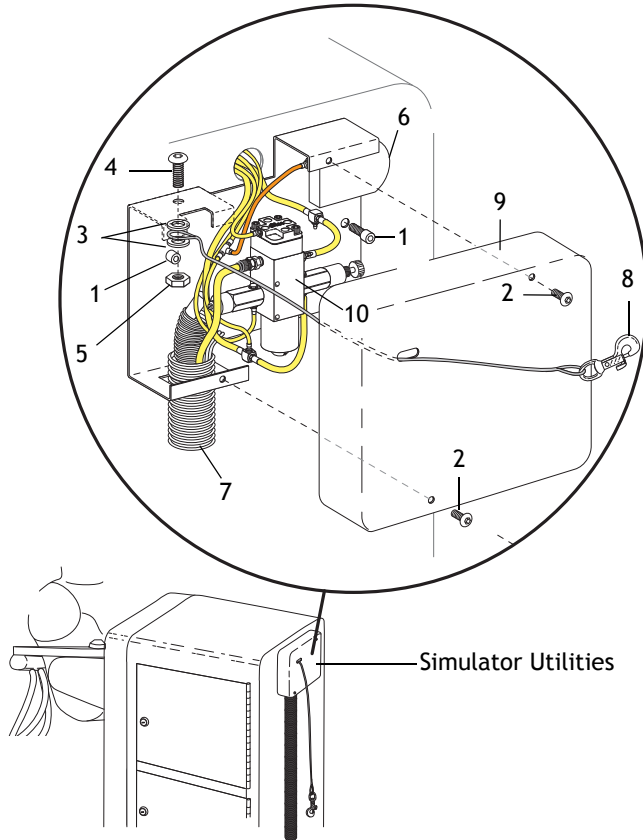
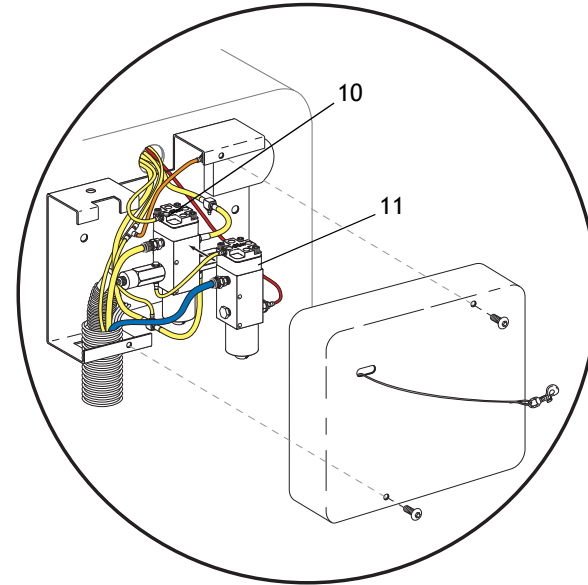

Figure 9 Utilities with Water Filter/Regulator - City Water



Mobile Simulator Utilities - Bench Mounted

Part No: 83.0313.00 and 83.0487.00

Item	Part Number	Description
1	026.022.00	QD, 3/8" Female
2	83.0145.00	Umbilical bracket
3	027.020.00	Thumbscrew knob (2)
4	002.135.00	Socket head screw
5	006.052.00	Lock nut
6	P05.001.01	Eye bolt
7	83.0215.00	QD Valve, Vacuum
8	004.180.00	Washer, Nylon
9	83.0214.00	Barb, 5/8"OD X 3/4" Hose
10	83.0317.00	Cable Assembly
11	83.0316.00	QD, 1/8" Female
12	026.001.00	QD, 1/4" Female
13	83.0203.00	Cover, Umbilical Bracket

Figure 10 Mobile Simulator Utilities - Bench Mounted

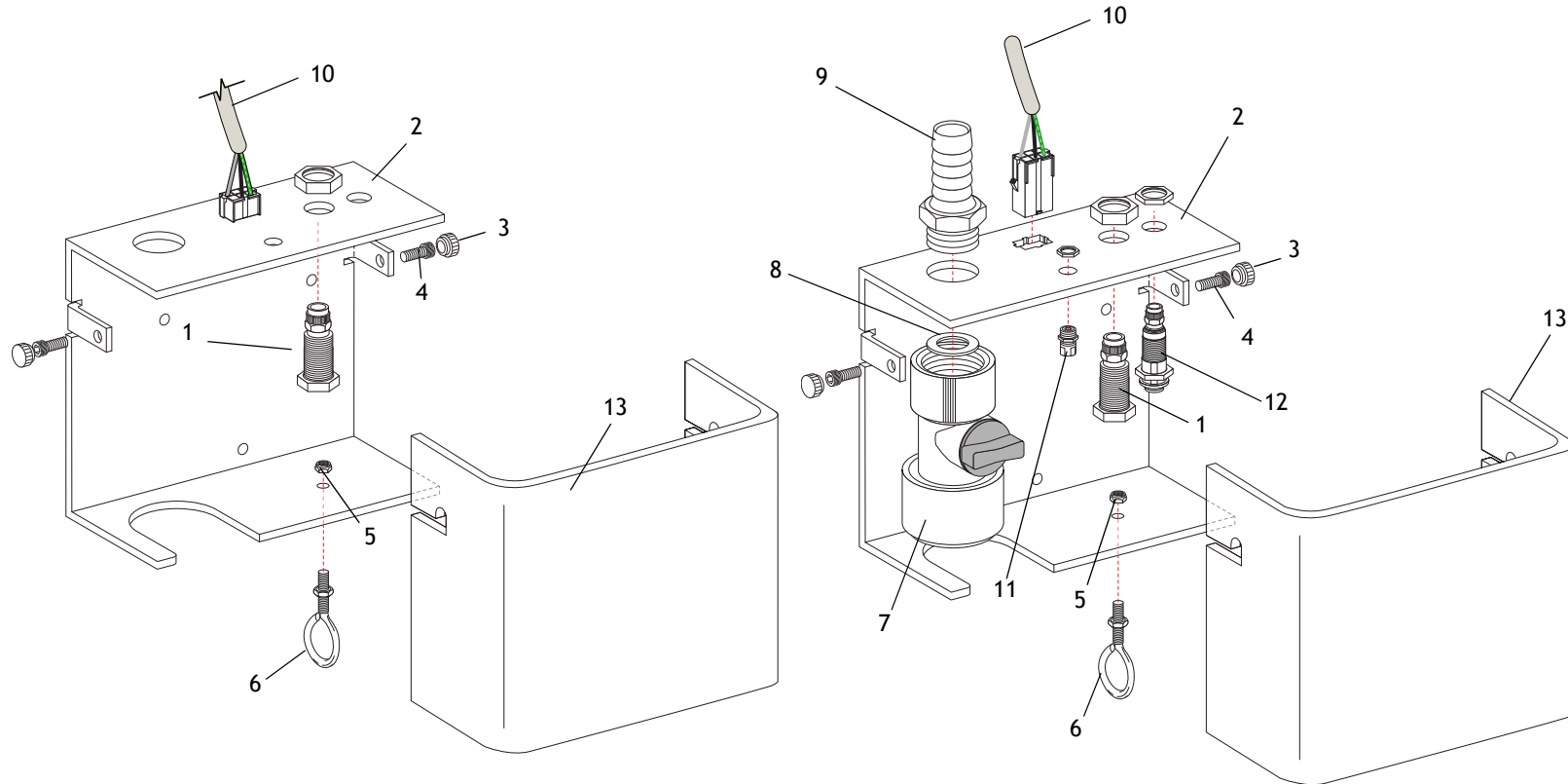

Air and Electric Only Utilities (83.0313.00)

Air, Water, and Vacuum Utilities (83.0487.00)

Mobile Simulator Vacuum Generator and Muffler Tray

Part No: 83.0142.00

Item	Part Number	Description
1	002.089.01	Screw, socket head
2	39.1190.00	Muffler
3	002.034.01	Screw, socket head
4	018.019.00	Vacuum seal
5	11.1083.00	Vacuum Generator
6	005.012.03	Screw, button head

Figure 11 Mobile Simulator Vacuum Generator and Muffler Tray Assembly

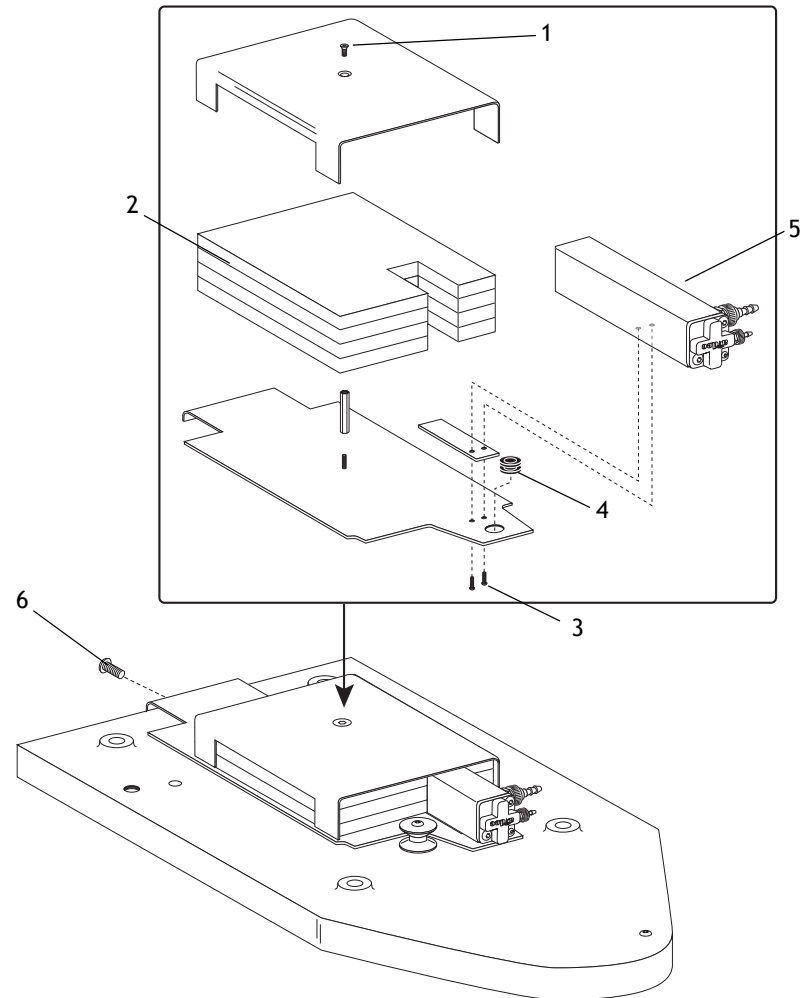

Mobile Simulator base is shown upside down for clarity. The assembly slides out, so there is no need to turn the Simulator over to access the tray assembly.

Mobile Simulator Lift Cylinder and Casters**Part No: 39.1125.00 (Lift Cylinder) and 65.1625.03 (Casters)**

Item	Part Number	Description
1	001.016.01	Screw
2	004.005.02	Nylon washer (package of 10)
3	005.135.00	Hex head screw
4	010.068.00	Retaining ring
5	013.105.00	Spring
6	017.023.00	Bumper
7	023.004.03	Barb 1/8" (package of 10)
8	030.011.02	O-ring (package of 10)
9	039.105.00	U-cup
10	39.1126.00	Cylinder
11	39.1127.00	Mount
12	39.1128.00	Spring retainer
13	65.1625.03	Caster (package of 5)
14	83.0353.00	Foot control carrier
15	005.138.00	Screw

Figure 12 Mobile Simulator Lift Cylinder and Casters

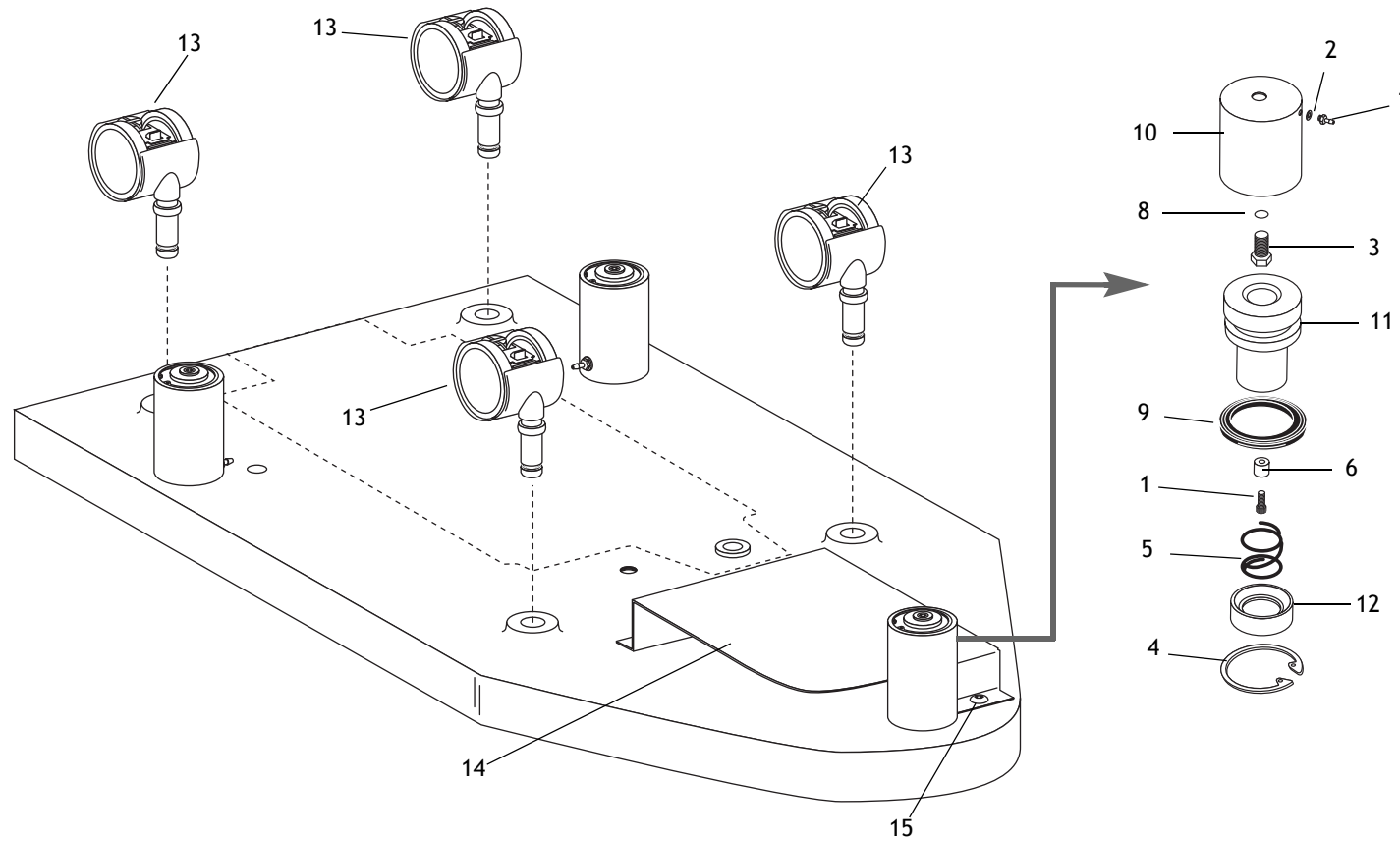

Mobile Simulator base shown upside down for clarity.



A-DEC STATIONARY SIMULATOR

The A-dec Stationary Simulator Model 4820 provides a training center for dental students and can be used with a variety of manikins (described on page 45). This chapter includes Stationary Simulator flow diagrams and illustrated parts breakdowns.

Figure 13 A-dec Stationary Simulator Model 4820

STATIONARY SIMULATOR CONTENTS

- Flow Diagrams, page 28
- Illustrated Parts Breakdown, page 33

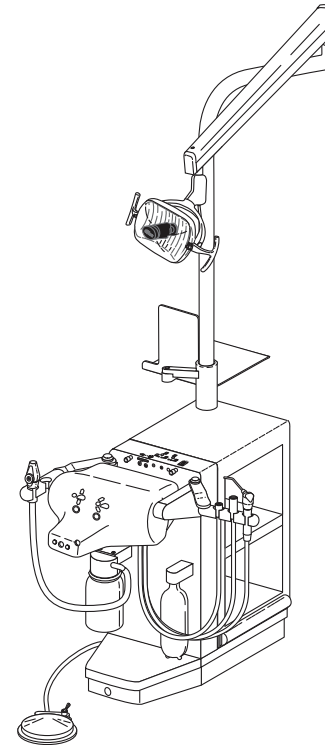

Flow Diagrams

The A-dec Stationary Simulator comes with or without the self-contained water system, with either an air vacuum system (AVS) or a central vacuum, and with either a standard control block or the Century Plus control block. This section includes flow diagrams showing these configurations.

STATIONARY SIMULATOR FLOW DIAGRAMS

- Stationary Simulator, Self-contained Water, Standard Block, page 29
- Stationary Simulator, City Water, Standard Control Block, page 30
- Stationary Simulator, Self-contained Water, Century Plus Block, page 31
- Stationary Simulator, City Water, Century Plus Control Block, page 32

Stationary Simulator, Self-contained Water, Standard Block

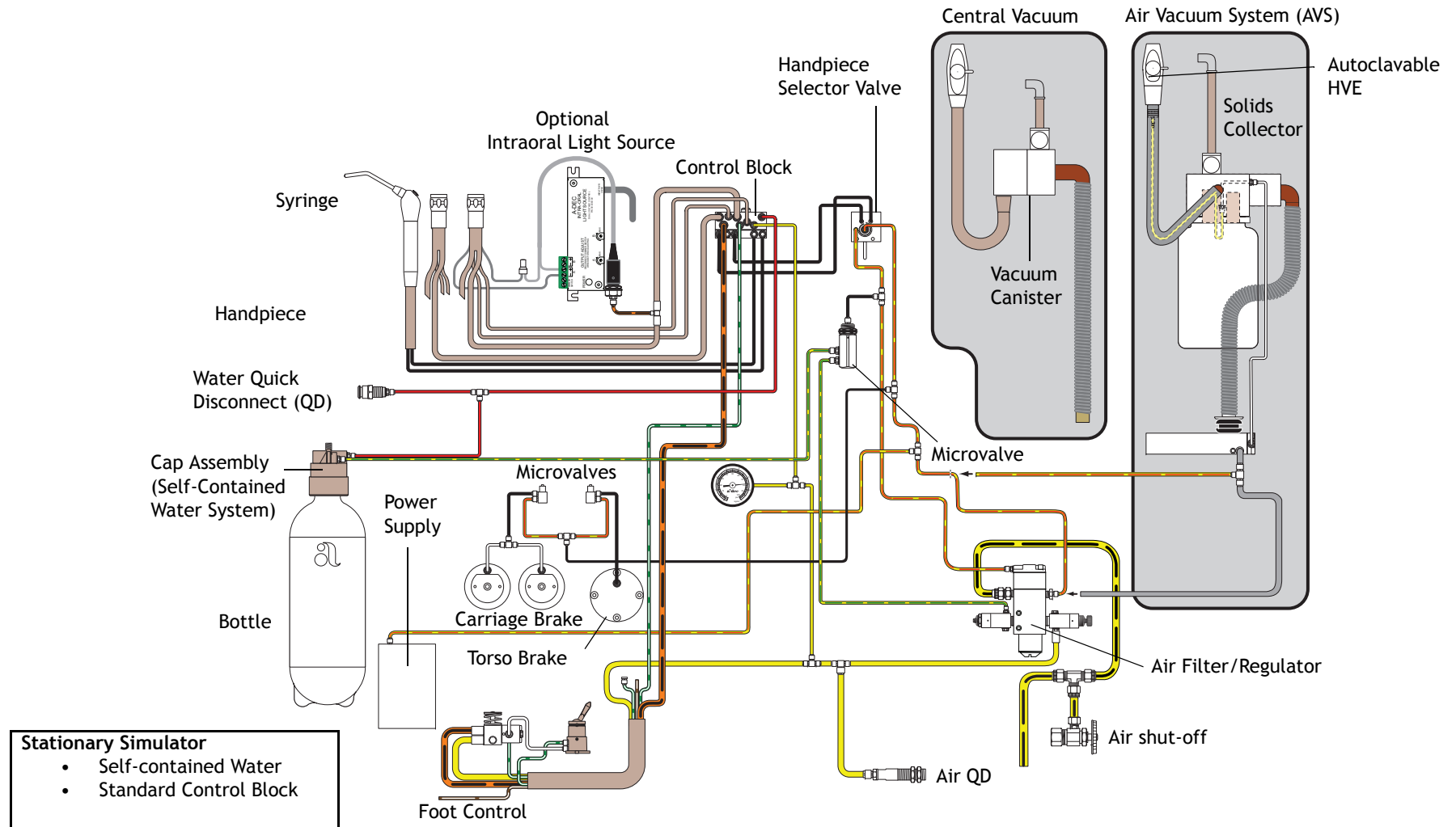

Stationary Simulator

Stationary Simulator, City Water, Standard Control Block

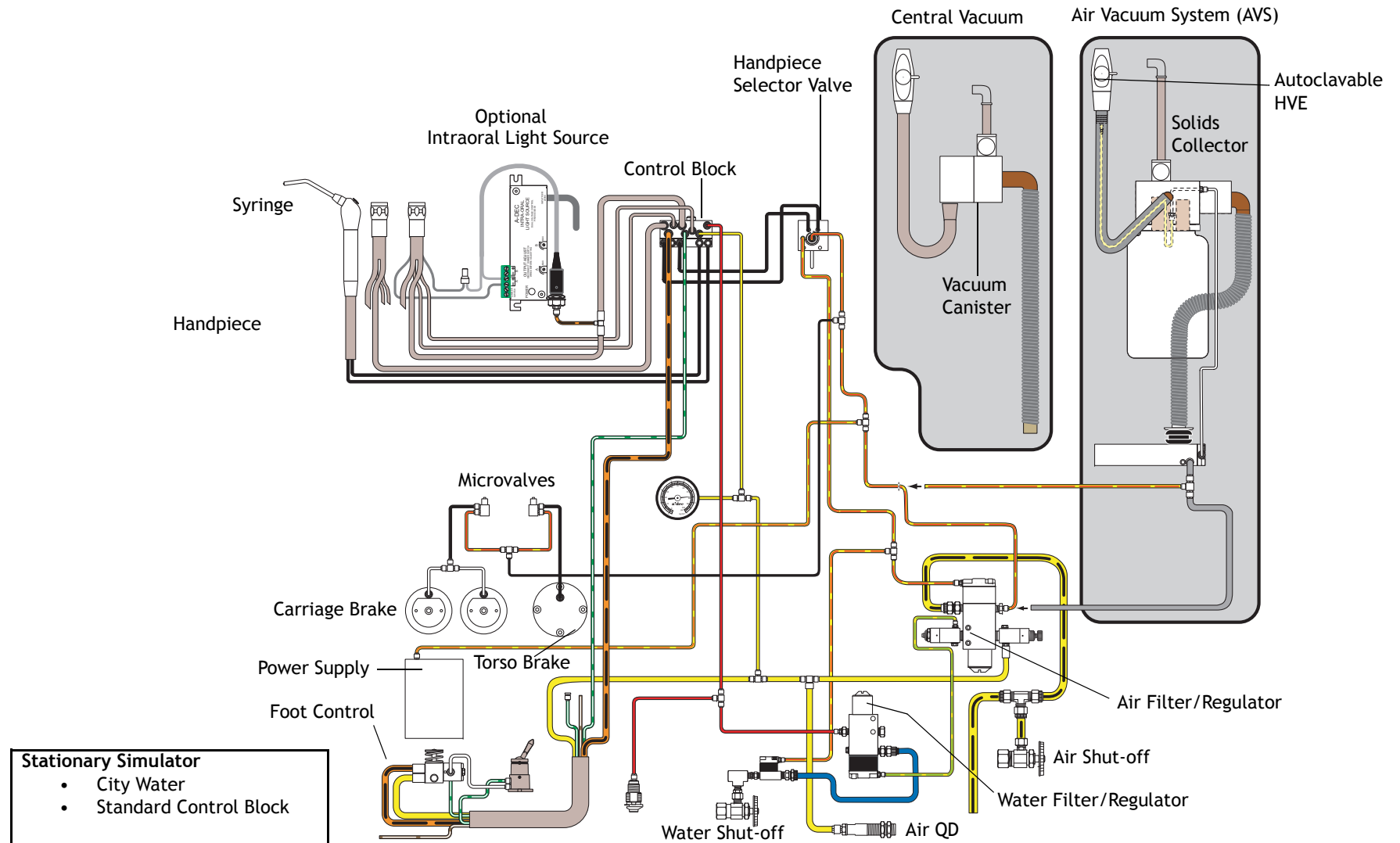

Stationary Simulator, Self-contained Water, Century Plus Block

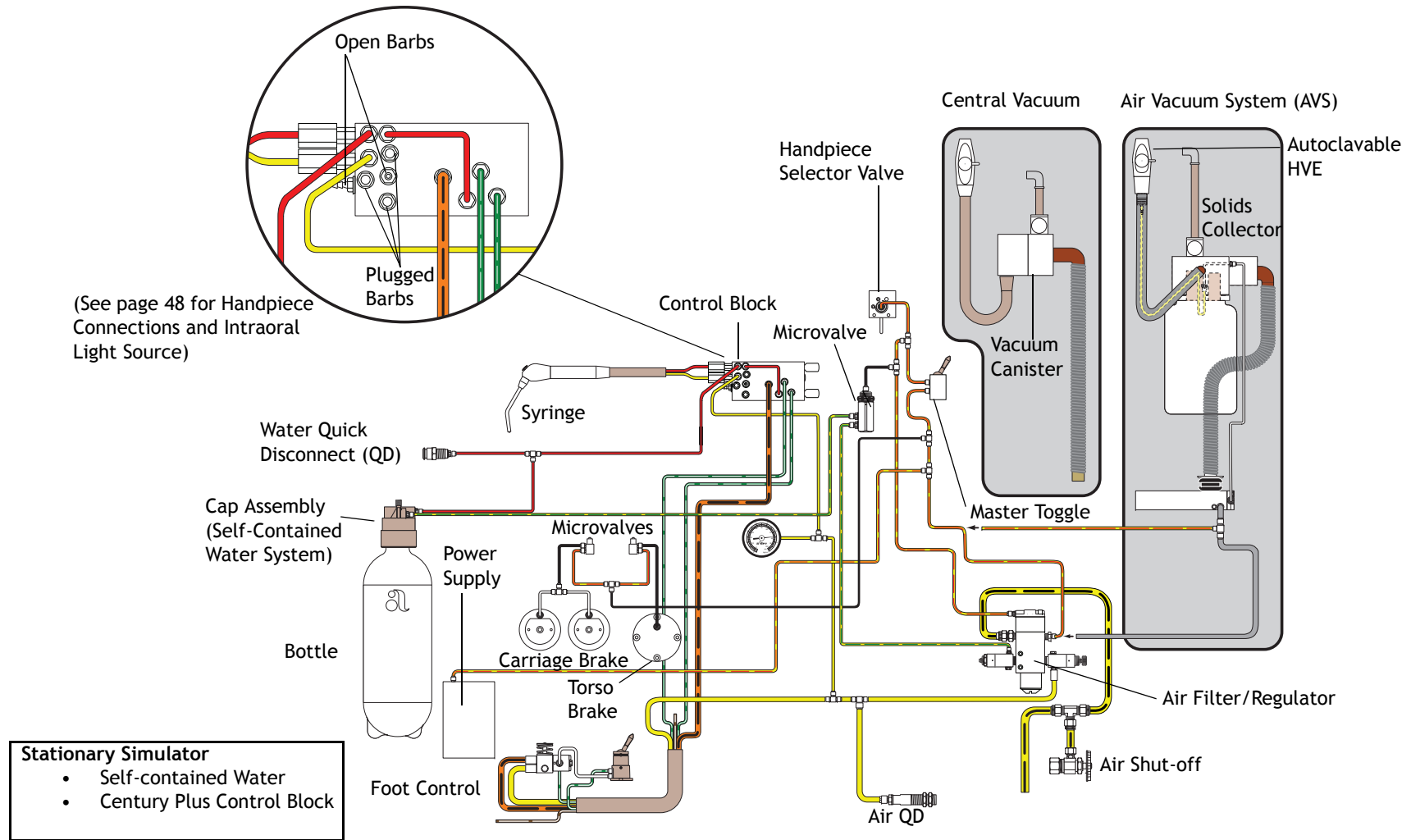

Stationary Simulator, City Water, Century Plus Control Block

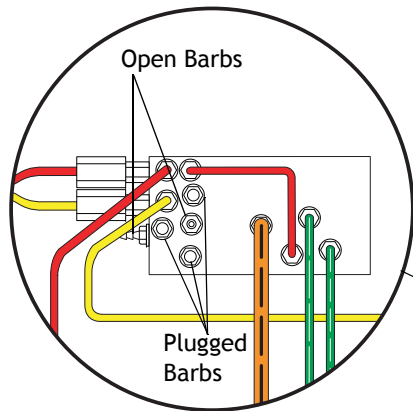

(See page 48 for Handpiece Connections and Intraoral Light Source)

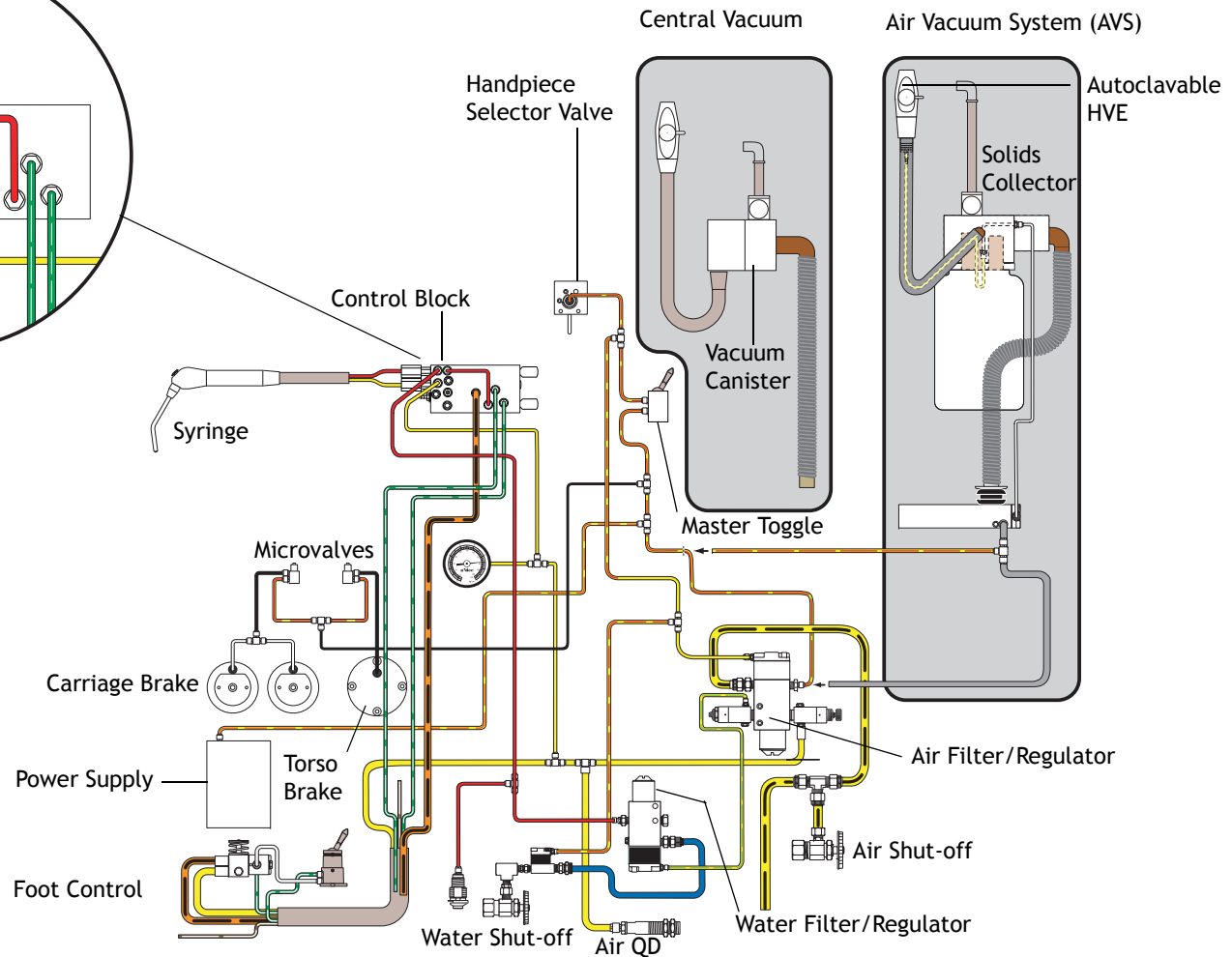

- Stationary Simulator**
- City Water
 - Century Plus Control Block

Illustrated Parts Breakdown

This section contains illustrated parts breakdowns for items related only to the A-dec Stationary Simulator Model 4820.

Part Identification Symbols

The conventions for the serviceable components tables are designed to identify all parts and kits, including ones that are not for sale. Symbols with reference notes are used.

Symbol	Definition
†	Indicates that the individual part is not available for sale. (These parts are typically part of a kit or larger assembly that is for sale.)
*	The part belongs to a kit.
No symbol	Part is for sale.

STATIONARY SIMULATOR FLOW DIAGRAMS

- Stationary Simulator Vacuum Generator and Muffler Tray, page 34
- Writing Surface, page 36
- Monitor Mount, page 37

Stationary Simulator Vacuum Generator and Muffler Tray

Part No: 83.0148.00

Item	Part Number	Description
1	002.089.01	Screw, flat head
2	39.1190.00	Muffler
3	002.034.01	Screw, button head
4	018.019.00	Vacuum seal
5	11.1083.00	Vacuum generator assembly
6	11.1088.00	Spacer
7	42.0693.00	Standoff
8	005.007.01	Screw, button head
9	11.1123.00	Tray
10	39.1192.00	Guide
11	39.1193.00	Cover

Figure 14 Stationary Simulator Vacuum Generator and Muffler Tray Assembly

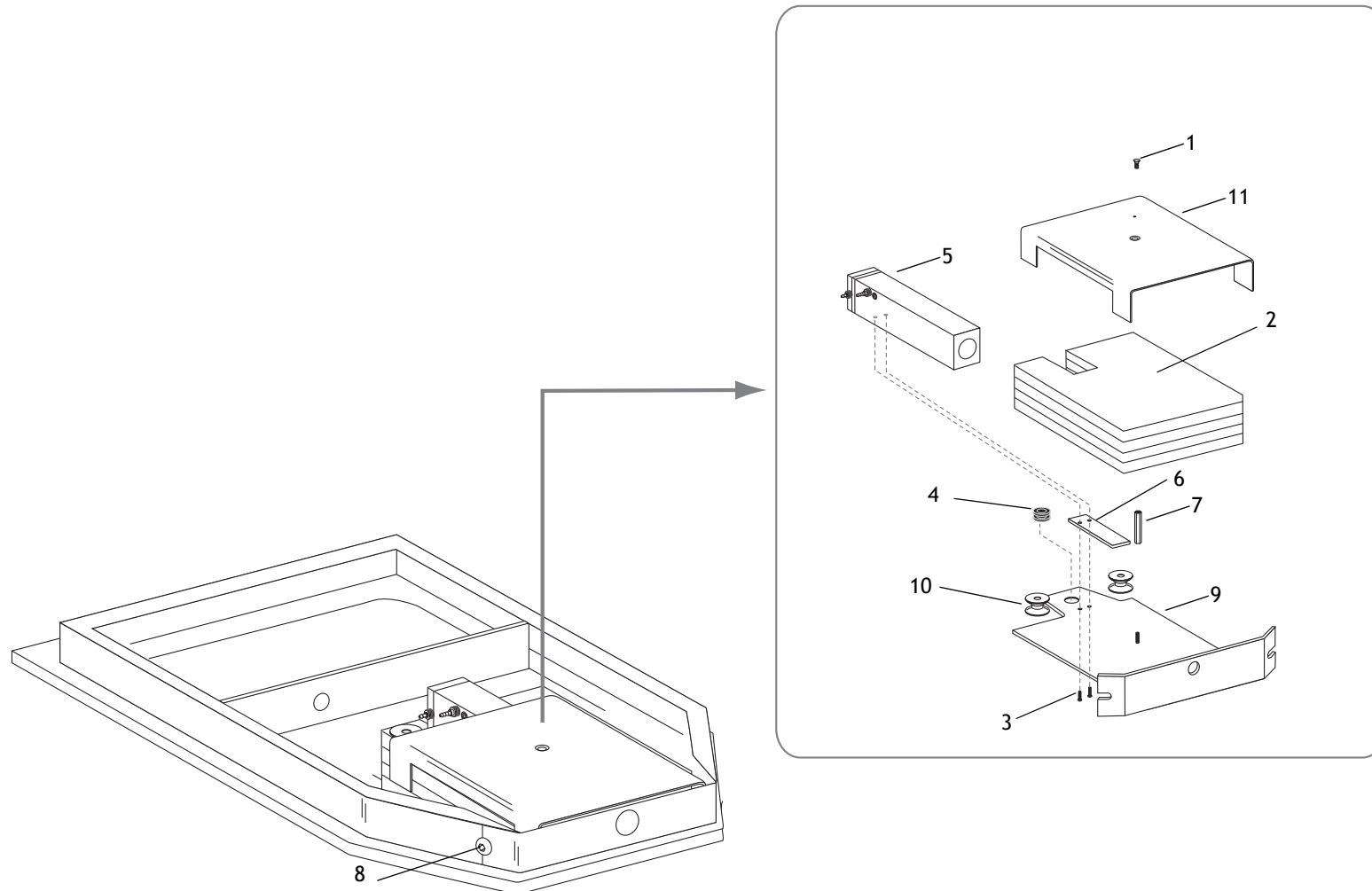

Stationary Simulator base shown upside down for clarity. There is no need to turn Simulator over to access the tray assembly.

Writing Surface

This feature is optional.

Part No: 83.0322.00

Item	Part Number	Description
1	004.022.00	Spring washer
2	004.034.00	Flat washer
3	004.136.00	Thrust washer
4	016.033.00	Thrust needle bearing
5	35.0089.00	Special screw
6	83.0323.00	Weldment
7	83.0325.00	Pivot washers (requires 2 per assembly)
8	83.0327.00	Writing Surface

Figure 15 Writing Surface Feature

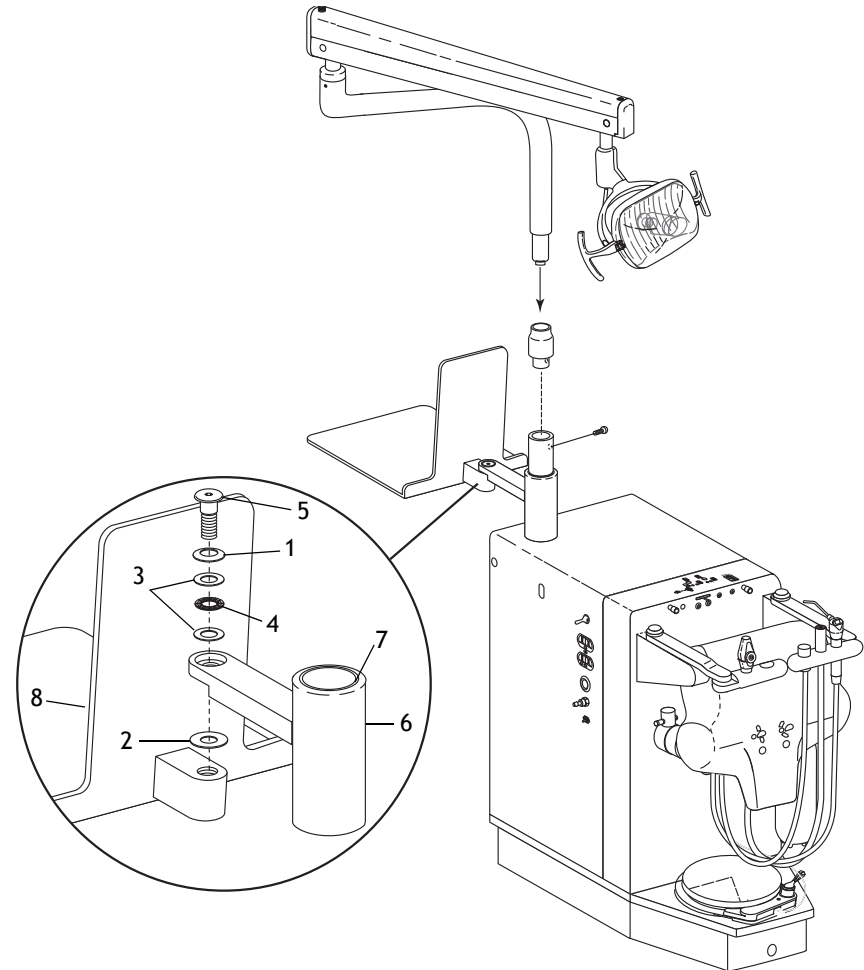

Monitor Mount

The monitor mount is an optional feature.

Part No: 83.0394.00

Item	Part Number	Description
1	83.0401.00	Mounting plate
2	002.042.00	Screw
3	011.062.00	Pin
4	004.054.00	Washer
5	61.0816.00	Bearing
6	83.0403.00	Clamp
7	010.024.00	Ring
8	83.0404.00	Cap
9	007.001.00	Set screw
10	001.088.00	Screw
11	004.172.00	Thrust washer
12	006.130.00	Nut
13	016.102.00	Thrust bearing
14	83.0406.00	Clamp cover
15	002.140.00	Screw
16	001.237.00	Screw
17	83.0439.00	Arm

Figure 16 Monitor Mount

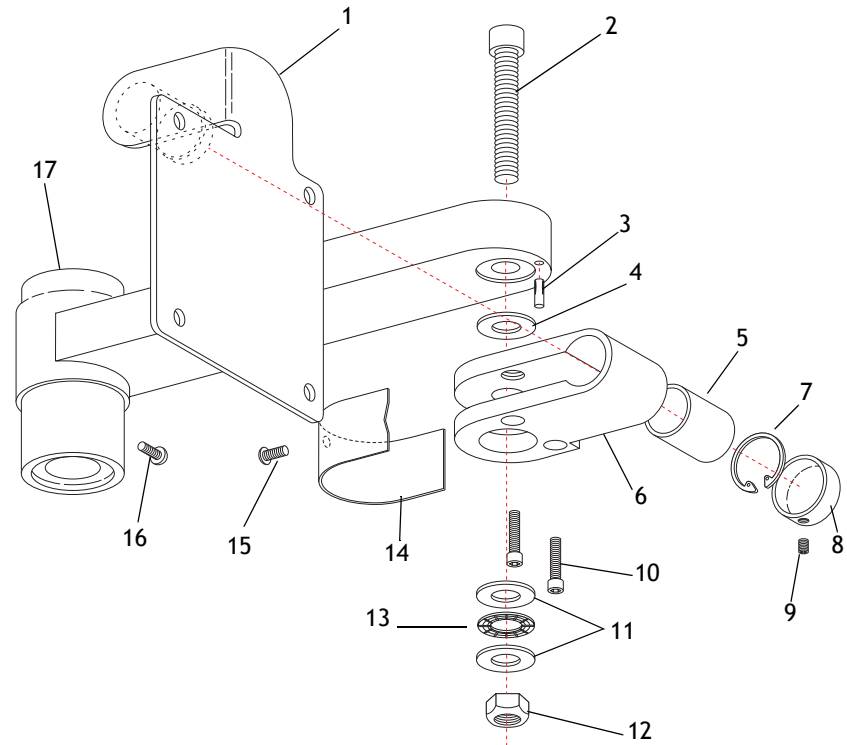



CROSS-SYSTEM FEATURES

This section contains information about components and system accessories that pertains to both A-dec Simulator models.

CROSS-SYSTEM FEATURES CONTENTS

- **Overview**
 - A-dec, page 41
 - Handpiece, page 44
 - Manikins, page 45
- **Flow Diagrams**
 - Intraoral Light, Standard Control Block, page 47
 - Intraoral Light, Century Plus Control Block, page 48
 - EA-40LT Electric Micromotor, page 49
- **Service/Usage**
 - Accessing the Carriage Assembly, page 50
 - Using the EA-40LT Electric Micromotor, page 51
- **Adjustments and Maintenance**
 - Making Handpiece Adjustments, page 53
 - Making Syringe Adjustments, Standard Control Block, page 55
 - Making Syringe Adjustments, Century Plus Control Block, page 55
 - Adjusting the A-dec Dual Voltage Intraoral Light Source, page 56
 - Adjusting the Torso Brake (Rotation), page 57
 - Adjusting the Headrest and Back Assembly, page 58

- **Illustrated Parts Breakdown**
 - Carriage Assembly, Standard Control Block, page 60
 - Carriage Assembly, Century Plus Control Block, page 61
 - Standard Simulator Control Block Assembly, Two Handpiece, page 62
 - Century Plus Simulator Control Block, page 63
 - Master Toggle – Century Plus Control Block Only, page 65
 - Century Plus Simulator Control Block Manifold, page 64
 - Handpiece Selector Valve, Two Handpiece, page 66
 - Handpiece Selector Valve, Three Handpiece, page 67
 - Foot Control Wet/Dry Toggle Valve, page 68
 - Foot Control Valve Assembly, page 69
 - Autoclavable Syringe, page 70
 - Autoclavable HVE Standard Assembly, Central Vacuum, page 71
 - Simulator Vacuum Generator Assembly, page 72
 - AVS Valve Assembly, page 73
 - Vacuum Canister/AVS Lid, page 74
 - Torso Brake Parts, page 76
 - Air Filter/Regulator and Water Filter/Regulator, page 78
 - Air-actuated Water Shutoff Valve, page 80
 - Button Valve, page 82
 - Handpiece Holder Arms, page 84
 - Tray Holder, page 85
 - Headrest and Back Assembly, page 86
 - 17 Watt Power Supply, page 91
 - 25 Watt Power Supply, page 92
 - 300 Watt Power Supply, page 94

Overview

A-dec Tubing







As an option, some simulators come with silicone handpiece tubing. The silicone handpiece tubing uses a European color code for air (blue) and water (green) that differs from the current U.S. standard.

Table 7 Silicone Handpiece Tubing Cross Reference Table

Color	Function
Clear	Drive air
Red	Exhaust
Blue	Air coolant
Green	Water coolant

Table 8 lists functions, descriptions and part numbers. Identify tubing functions by reading the tubing color and tracer markings.

Table 8 A-dec Tubing Identification

Function	Description	Color/Tracer	Part Number
Chip blower/accessory button	Chip blower air - 1/8" OD, brown/white long dash		036.014.02 (10')
Air coolant signal	Air coolant signal air from foot control - 1/8" OD, green/white long dash		036.006.03 (10')
Water coolant signal	Water coolant signal air from foot control - 1/8" OD, green/white short dash		036.018.03 (10')
Water	Water Supply - 1/8" OD, red		036.005.03 (10')
Unregulated air, master air	Continuous, filtered, unregulated air - 1/8" OD from the air filter/regulator to the master On/Off toggle, yellow/red stripe		036.013.03 (10')
Pilot air	Filtered unregulated air controlled by master On/Off toggle - 1/8" OD, yellow/red dash		036.009.04 (10')
Regulated air	Continuous, filtered, regulated air - 1/8" OD, yellow		036.003.03 (10')

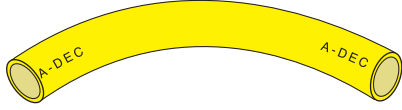
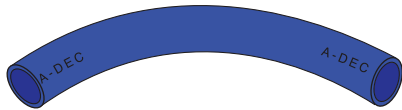
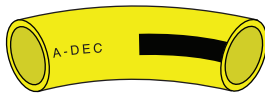
Function	Description	Color/Tracer	Part Number
Drive air	Drive air from foot control to delivery system - 1/4" OD, orange		036.052.00 (10')
Regulated air	Supplies regulated air to the foot control - 1/4" OD, yellow		036.103.00 (10')
Water supply	Supplies unregulated water from the water supply to the water regulator - 1/4" blue		036.053.03 (10')
Unregulated air	Supplies unregulated air from the shutoff on the Air Manifold to the Air Regulator - 3/8" yellow/black dash		036.032.02 (10')

Handpiece

Surf 6 Handpiece (7') with Terminal Assembly

Figure 17 Handpiece Tubing with Midwest Terminal, 4 hole

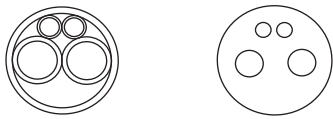

Vinyl Tubing 98.0879.00; Silicone Tubing 98.1004.00

Figure 18 Handpiece Tubing, Fiber Optic with Bulb

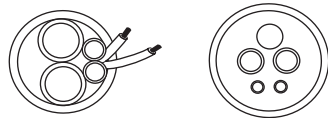

Vinyl 98.0262.02; Silicone 98.1005.00

Figure 19 Handpiece Tubing with Borden Terminal, 3 Hole

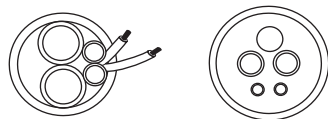

Vinyl Tubing 98.0882.00; Silicone Tubing 98.1003.00

Figure 20 Handpiece Tubing, fiber optic, 6-pin

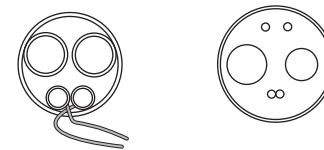

Vinyl Tubing 98.0885.00; Silicone Tubing 98.1006.00

Figure 21 Cross-section Tubing from the Control Block

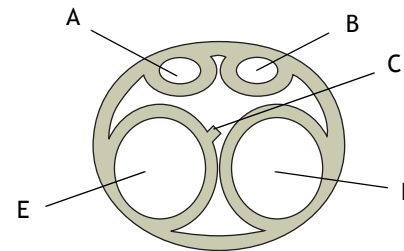

(A) Coolant Water; (B) Coolant Air; (C) RIB (Identifier Drive Air Tubing);
(D) Exhaust; (E) Drive Air (Ribbed)

Manikins

A-dec Simulator mount and drain kits support the Columbia, Kilgore and Frasco manikins. Table 9 lists the part numbers. Figure 22 through Figure 26 show the differences.

Manikin Part Numbers

Table 9 Manikin Part Number

Part Number	Description
83.0166.00	Columbia I and Kilgore I, mount and drain kit
83.0165.00	Frasaco I, mount and drain kit
F84J.115	Columbia II, mount kit only
83.0155.00	Columbia II, drain kit
83.0167.00	Kilgore II, drain kit
	Kilgore II, mount kit (supplied with manikin)
83.0462.00	Frasaco II, mount and drain kit

Figure 22 Columbia I and Kilgore I Manikin Drain Assembly

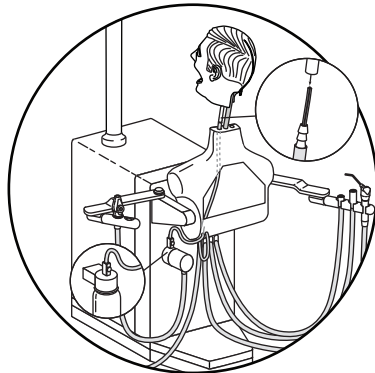

Figure 23 Frasco I

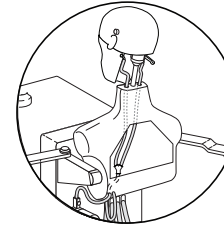

Figure 24 Columbia II

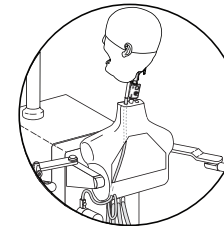

Figure 25 Kilgore II

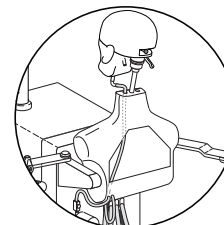
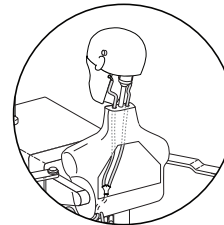

Figure 26 Frasco II



Flow Diagrams

This section contains illustrated parts breakdowns for items common to both the A-dec Mobile Simulator and the A-dec Stationary Simulator.

CROSS SYSTEM FLOW DIAGRAMS

- Intraoral Light, Standard Control Block, page 47
- Intraoral Light, Century Plus Control Block, page 48
- EA-40LT Electric Micromotor, page 49

Intraoral Light, Standard Control Block

The intraoral light is an optional feature.

Figure 27 A-dec Dual Voltage Intraoral Light Source and Power Supply Electric Diagram

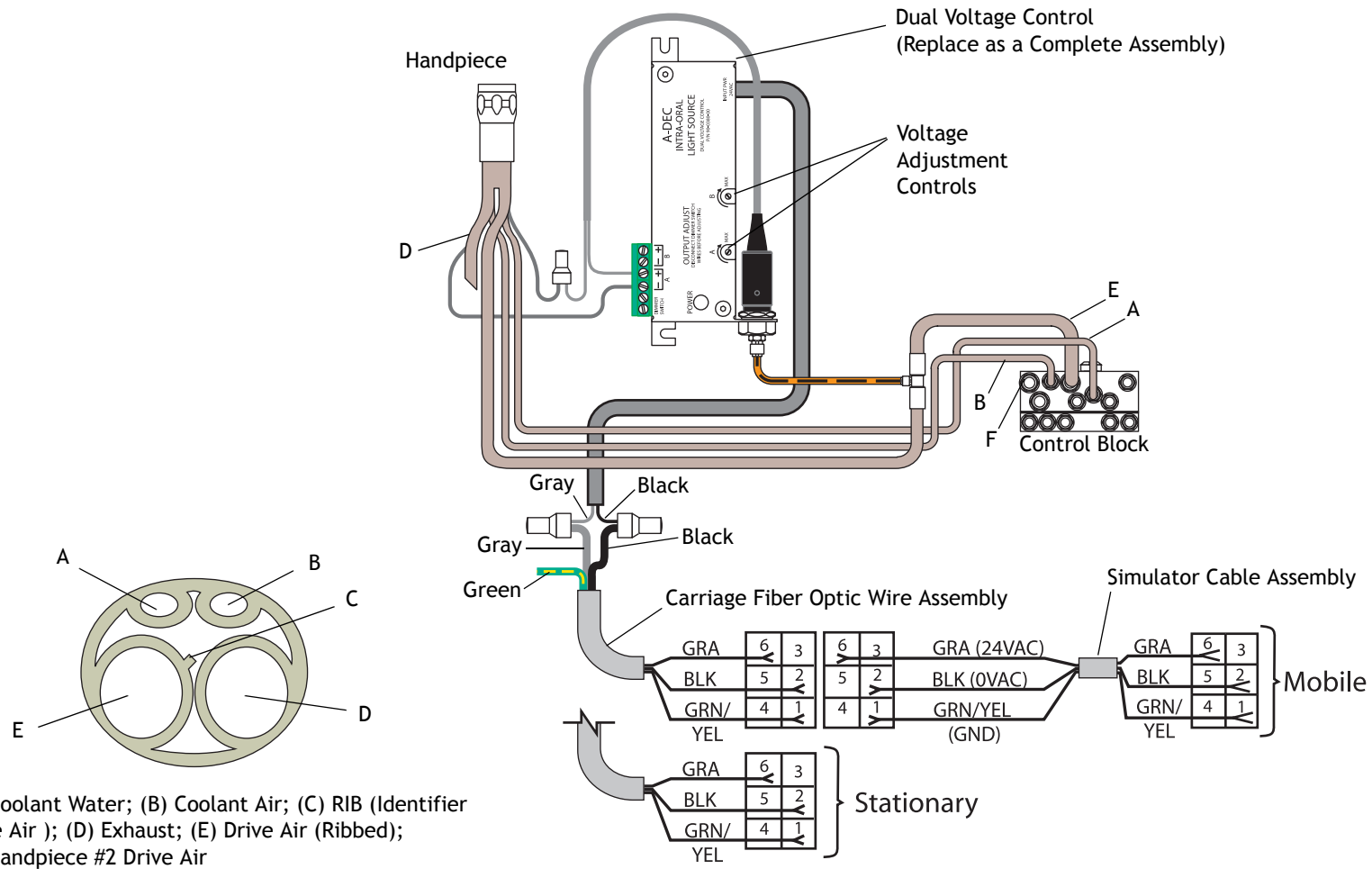

Intraoral Light, Century Plus Control Block

The intraoral light is an optional feature.

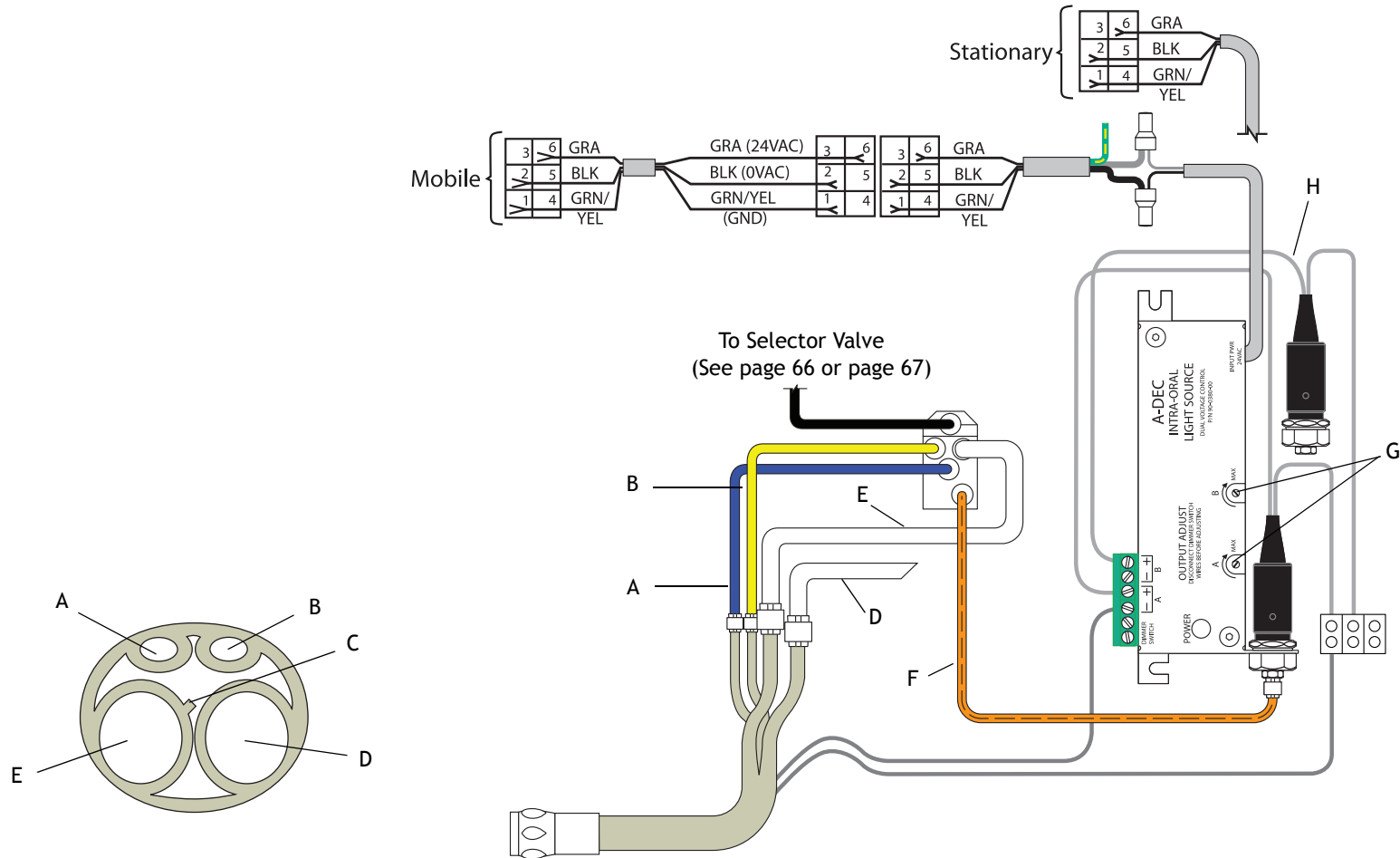

(A) Coolant Water; (B) Coolant Air; (C) RIB (Identifier Drive Air); (D) Exhaust; (E) Drive Air (Ribbed); (F) Fiber Optic Signal; (G) Voltage Adjustment Controls; (H) Second Fiber Optic Position (Optional)

EA-40LT Electric Micromotor

The EA-40LT electric micromotor is an optional feature.

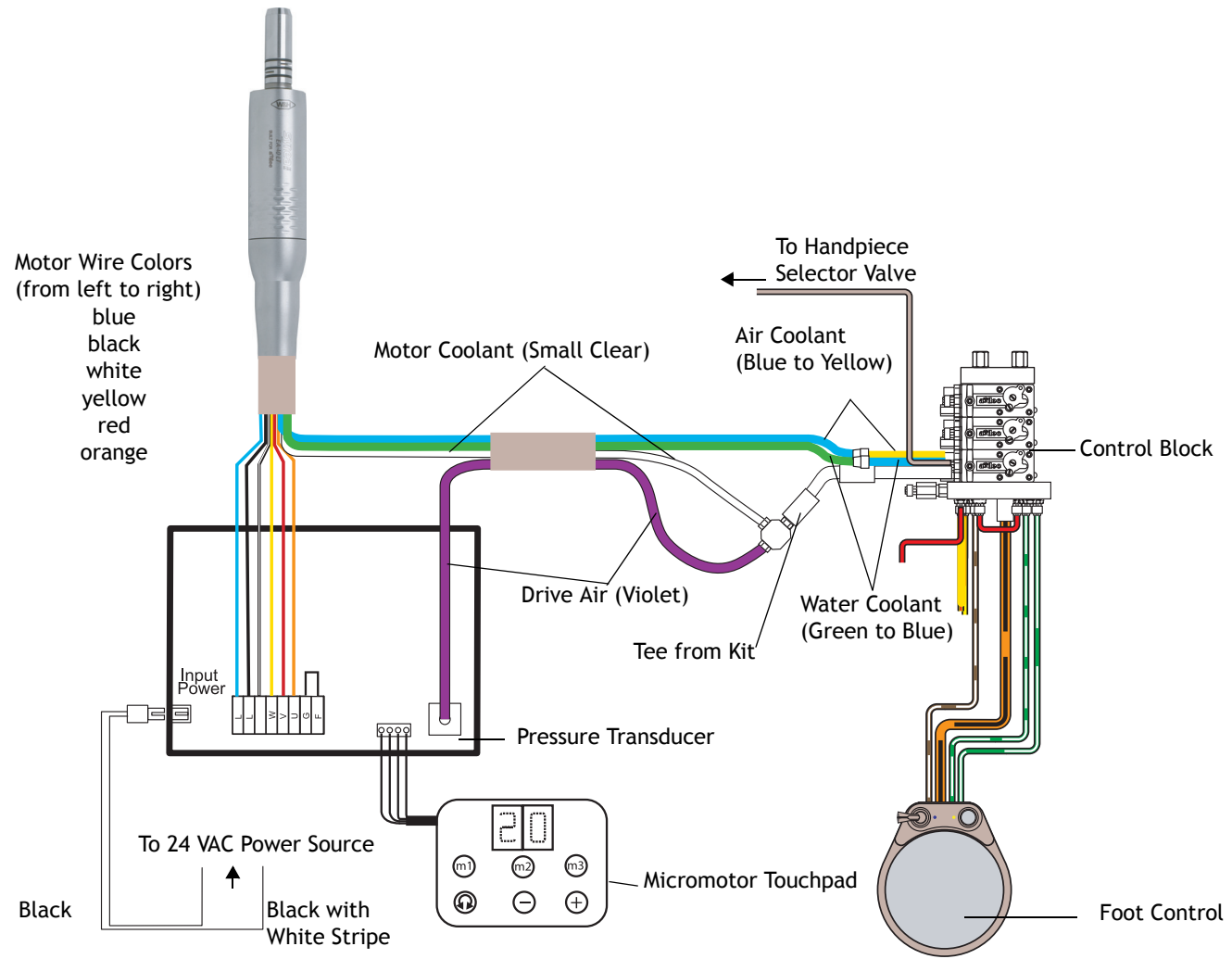

Service/Usage

This section contains service and usage information for some of the cross-system features.

CONTENTS

- Accessing the Carriage Assembly, page 50
- Using the EA-40LT Electric Micromotor, page 51

Accessing the Carriage Assembly

1. Secure the carriage assembly to the Simulator box using a strong, light rope or a strong, pliable wire.
2. While holding the carriage assembly, remove the six hex screws inside the Simulator box.
3. Slowly tilt the carriage assembly away from the Simulator box.
4. Make sure the rope/wire is installed so that it does not slip when you let go of the carriage assembly.

Figure 28 Accessing the Carriage Assembly

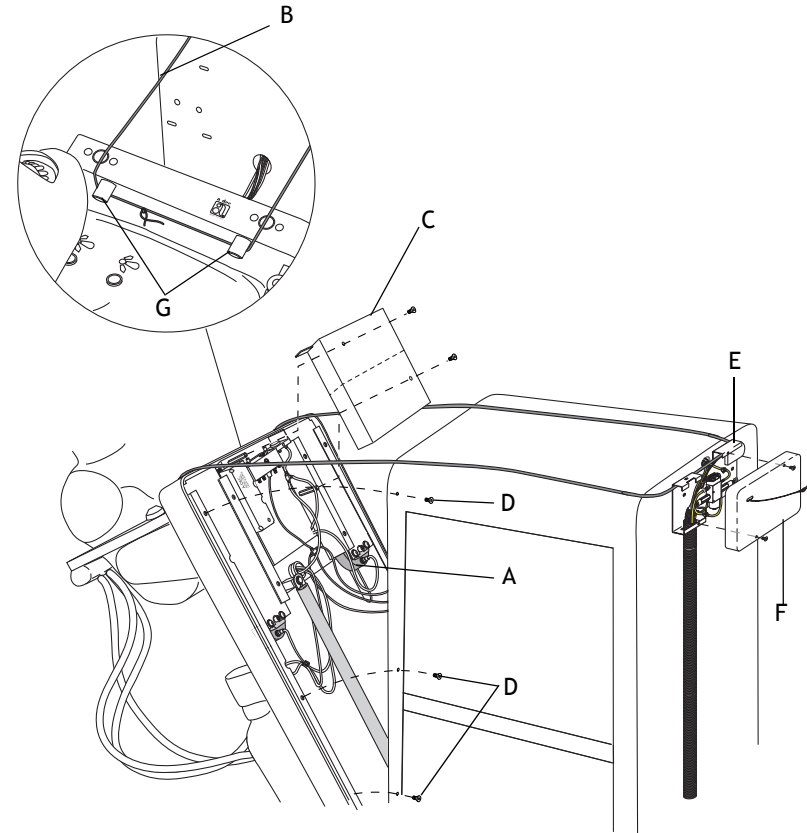

- (A) Carriage Brake Assembly; (B) Rope or Strong, pliable wire; (C) Control Block Cover; (D) Hex Screws; (E) Utilities Bracket; (F) Utilities Cover; (G) Torso Bumper

Using the EA-40LT Electric Micromotor

■ Before Use

If your system has the optional micromotor, follow these steps:

1. Check the motor for damage and loose parts before and between uses.
2. Check that air and water coolant spray are set correctly.

■ Install the Motor

1. Position the motor connection tubes with the connection openings on the handpiece .
2. Press the motor and the together until you hear two clicks.
3. If the motor fails to connect, remove it from the . Push back the nut to the stop and repeat steps 1 and 2.
4. Verify that the motor has engaged the securely. The motor and should not separate with a gentle pull.

■ Install the Handpiece



WARNING Do not connect or remove the handpiece while the motor is running.

1. Push the handpiece onto the motor. If the handpiece is fiber-optic, be sure to line up the notch.
2. Check for a secure hold on the motor. The handpiece should not come off with a gentle pull.

■ Test Run

1. Start the motor by depressing the foot control.
2. If you observe vibrations, unusual noise, heating, smell or leakage, contact A-dec for assistance.

■ Program the Touchpad

1. Press and hold a program key (M1, M2, M3) while adjusting the speed up or down with the + and - keys.
2. When the speed value is not changed for more than three seconds, it is stored to that corresponding program key.
3. Press the key to change the motor direction. In clockwise operation, the display is static. In counterclockwise operation, the display flashes. After three seconds, the direction is stored. Changing the motor direction affects all three programs.
4. Change from one program to the other by pressing the program keys, M1, M2 or M3.
5. Press all three program keys at the same time to restore the factory settings.

■ Clean and Disinfect the Motor

1. Wear protective gloves.
2. Remove the handpiece from the motor by pulling the two apart.
3. Carefully wipe the exterior of the micromotor with a soft cloth using only commercially available surface disinfectants or 80% ethyl alcohol.
4. Dry the motor completely.

■ Sterilize the Motor

1. Purge the water lines with air.
2. Remove the motor from the by pushing the nut back up to the stop while pulling the motor off the handpiece .
3. Place the motor in sterile goods packaging.
4. Sterilize the motor in a water stream sterilizer with a vacuum for ten minutes at 134° C (273° F).
5. Be sure the motor is dry before removing it from the sterilizer.

Adjustments and Maintenance

This section contains adjustment and maintenance information for some of the cross-system features.

CROSS-SYSTEM ADJUSTMENTS AND MAINTENANCE CONTENTS

- Making Handpiece Adjustments, page 53
- Making Syringe Adjustments, Standard Control Block, page 55
- Making Syringe Adjustments, Century Plus Control Block, page 55
- Adjusting the A-dec Dual Voltage Intraoral Light Source, page 56
- Adjusting the Torso Brake (Rotation), page 57
- Adjusting the Headrest and Back Assembly, page 58

Making Handpiece Adjustments

Figure 29 and Figure 30 shows the handpiece adjustment gauges for the Standard and Century Plus control blocks, and Table 10 defines the icons for these gauges.

Figure 29 Handpiece Selections, Standard Control Block

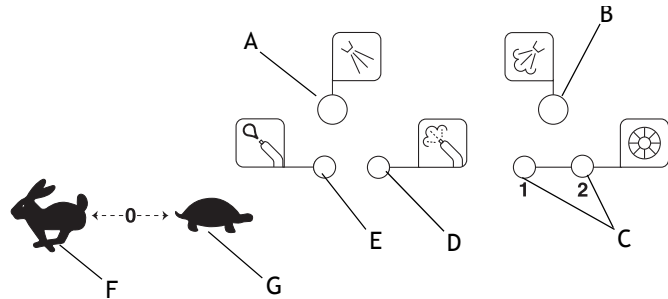

(A) Coolant Water Flow Control; (B) Coolant Air Flow Control; (C) Drive Air Pressure Flow Controls; (D) Syringe Air Flow Control; (E) Syringe Water Flow Control; (F) High Speed Handpiece; (G) Low Speed Handpiece

Figure 30 Handpiece Selections, Century Plus Control Block

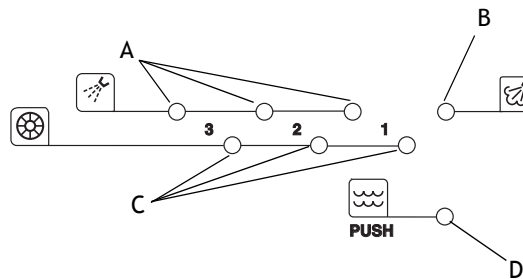

(A) Coolant Water Flow Control; (B) Coolant Air Flow Control; (C) Drive Air Pressure Flow Controls; (D) Flush Control

Table 10 Handpiece Adjustment Icons

Icon	Description	Icon	Description
	Coolant Water Flow Control		Syringe Air Flow Control
	Coolant Air Flow Control		Flush
	Drive Air Pressure Flow Controls		High Speed
	Syringe Water Flow control		Low Speed

■ Adjust Drive Air Pressure

The drive air pressure controls adjusts the drive air pressure to each handpiece. You must adjust the drive air control to meet the handpiece manufacturer's dynamic drive air pressure specification (refer to the documentation that came with your handpiece). To adjust the drive air pressure, use a 3/32" hex key and follow these steps:

1. Attach a handpiece pressure gauge to the handpiece nut, then connect the handpiece to the gauge.
2. Insert the hex key into the drive air control to be adjusted.
3. Move the foot control wet/dry toggle to the Off position (away from the blue dot).
4. Fully depress the foot control disc.
5. Turn the drive air control left until the handpiece is running at slightly above the specified drive air pressure, and then turn the control right until the handpiece runs at the specified drive air pressure.



NOTE Do not turn the control left beyond the point where the pressure increases. Doing so allows the control to come completely out of the unit.

6. Repeat steps 1 through 5 for each handpiece.

■ Adjust Coolant Air Flow

Use the coolant air flow control and an adjustment key or a 1/8" hex key to adjust the flow of coolant air to the high-speed handpiece. Follow these steps:

1. Insert the key into the coolant air control.
2. Move the wet/dry toggle on the foot control to the Off position (away from the blue dot).
3. Run the handpiece and turn the handpiece coolant air control. A strong flow is recommended. Turn the control right to decrease coolant air flow. Turn it left to increase coolant air flow.

■ Adjust the Coolant Water Flow

Use the coolant water flow controls and an adjustment key or a 1/8" hex key to adjust the flow of coolant water to the high speed handpiece. Follow these steps:

1. Insert the key into the coolant water control for the handpiece to be adjusted.
2. Turn the control right until it seats softly.
3. Move the foot control wet/dry toggle to the On position (toward the blue dot).
4. Run the handpiece at medium speed and turn the handpiece coolant water control until a fine mist is visible around the bur. Turn the control right to decrease coolant water flow. Turn it left to increase coolant water flow.

Making Syringe Adjustments, Standard Control Block

■ Adjust Syringe Flow, Standard Control Block

Use the syringe flow controls and a 3/32" hex key to adjust water and air flow to the syringe. Follow these steps:

1. Turn the control right to decrease flow.
2. Turn it left to increase flow.



NOTE Do not turn the control left beyond the point where the flow increases. Doing so allows the control to come completely out of the unit.

Making Syringe Adjustments, Century Plus Control Block

■ Adjust the Syringe Flow, Century Plus Control Block

Adjust the syringe air and water flow by turning the appropriate flow control while pressing the air button or water button on the syringe. To adjust them, follow these steps:

1. While facing the flow control, turn the control right to reduce air or water flow.
2. Turn the control left to increase the flow.

Adjust the syringe air and water flow to meet the Dental Teams' specified requirements.

Figure 31 Century Plus Control Block Manifold

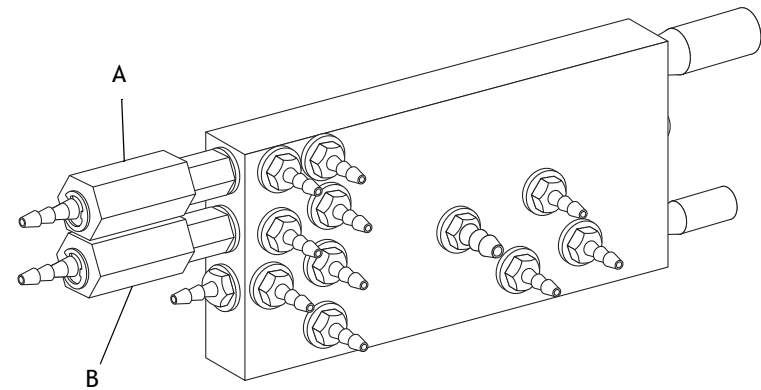

(A) Syringe Water Flow Control; (B) Syringe Air Flow Control

Adjusting the A-dec Dual Voltage Intraoral Light Source

■ Adjust the Intraoral Light Source

1. Set meter to measure Volts DC.
2. Turn the appropriate voltage adjustment control while the handpiece bulb is illuminated. (Refer to your handpiece manufacturer's specified requirements for the correct voltage.)

Figure 32 Dual Voltage Intraoral Light Source

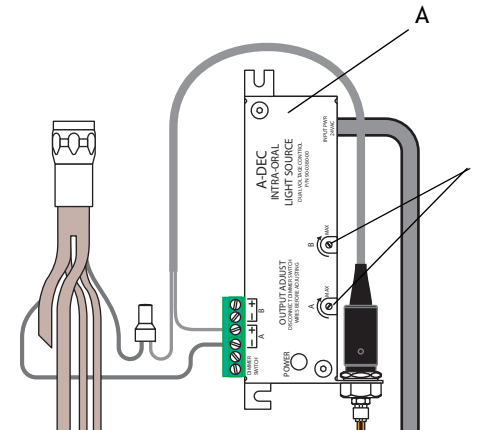

(A) Dual Voltage Control; (B) Voltage Adjustment Controls

Adjusting the Torso Brake (Rotation)

■ Adjust the Torso Brake using a 5/32" and a 3/32" Hex Key

1. Loosen, but do not remove, the torso brake adjustment screw.
2. Loosen, do not remove, the spring tension adjustment screw (so the spring is free).
3. Loosen, do not remove, the setscrew which secures the eccentric pin. To see a complete break down of the parts, refer to "Torso Brake Parts" on page 76.
4. Rotate the eccentric pin to its loosest position.
5. Turn the spring tension adjustment screw right to remove play on the spring, and then tighten the spring tension adjustment screw two full turns.
6. Depress the torso brake button while rotating the eccentric pin right to the point that any further adjustment causes the clamp to lockup or drag when the assembly is rotated back down.
7. Tighten the setscrew which secures the eccentric pin.
8. Turn the torso brake adjustment screw all the way in until it stops, and then back it out 1-1/4 turns.

■ Test the Torso Assembly Brake Adjustment

The brake assembly should not move with the brake set. The torso assembly should have 14 lb. to 10 lb. drag measured at the ball of the manikin head mount. If the torso assembly moves too freely, increase tension by turning the torso brake adjustment screw left in small increments. If the torso assembly moves with difficulty, decrease tension by turning the torso brake adjustment screw right in small increments.



NOTE If necessary, see the "Troubleshooting the Torso Brake" on page 32 for additional help.

Figure 33 Simulator Torso Brake Assembly and Location

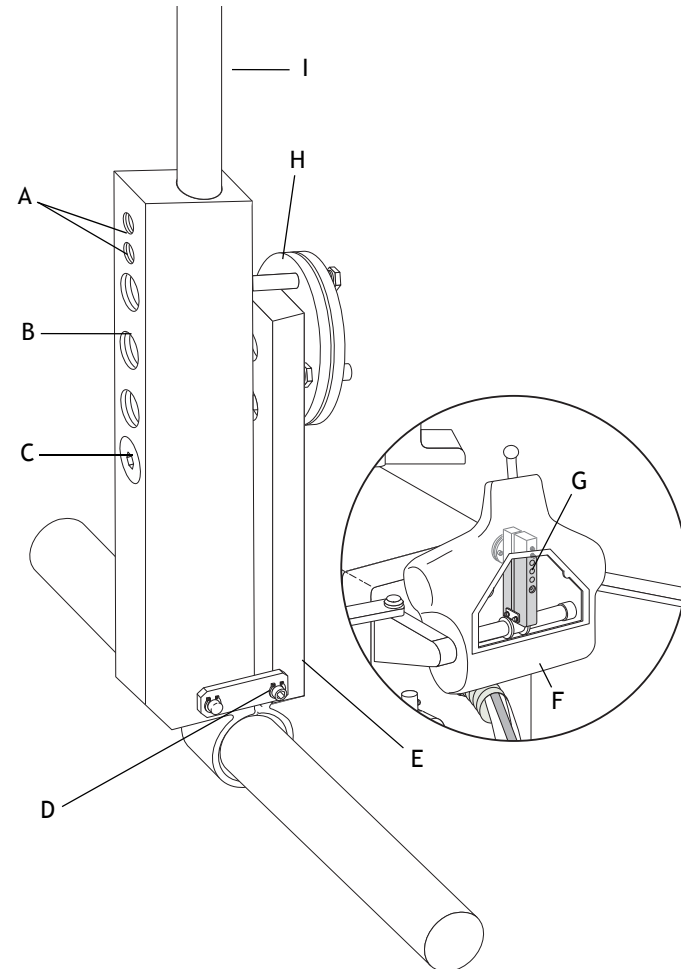

A) Set Screws (Manikin Head Mount); (B) Torso Brake Adjustment Screw; (C) Spring Tension Adjustment Screw (for Adjusting Torso Brake Spring Tension); (D) Eccentric Pin; (E) Setscrew (for Securing the Eccentric Pin); (F) Simulator Torso; (G) Torso Brake Assembly; (H) Torso Brake Cylinder; (I) Manikin Head Mount

Adjusting the Headrest and Back Assembly

■ Adjust the Headrest Glide Bar Tension

If your system has the optional headrest and back assembly, you can follow adjust the glide bar tension until the headrest moves freely yet maintains its position. Use a Hex key to adjust the glide bar tension:

- Turn the screws right to increase friction and hold the headrest more securely.
- Turn the screws left to decrease friction and allow the headrest to move up and down more freely.

Figure 34 Headrest Glide Bar Tension Adjustment

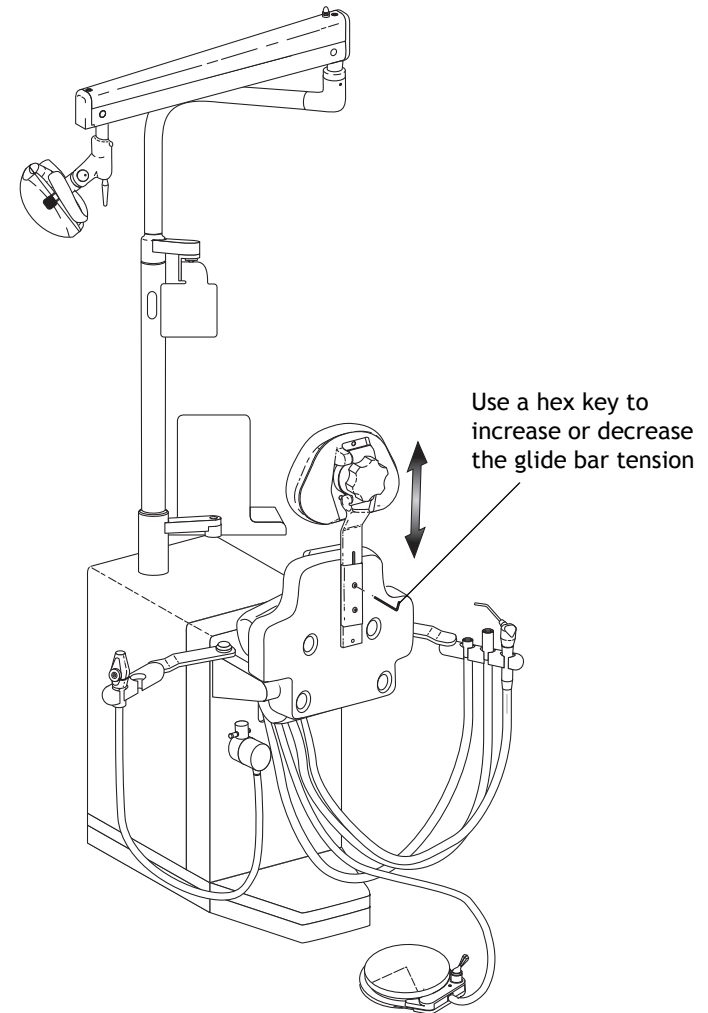

Illustrated Parts Breakdown

This section contains illustrated parts breakdowns for items related only to the A-dec Mobile Simulator Model 4810.

Part Identification Symbols

The conventions for the serviceable components tables are designed to identify all parts and kits, including ones that are not for sale. Symbols with reference notes are used.

Symbol	Definition
†	Indicates that the individual part is not available for sale. (These parts are typically part of a kit or larger assembly that is for sale.)
*	The part belongs to a kit.
No symbol	Part is for sale.

CROSS SYSTEM IPB CONTENTS

- Carriage Assembly, Standard Control Block, page 60
- Carriage Assembly, Century Plus Control Block, page 61
- Standard Simulator Control Block Assembly, Two Handpiece, page 62
- Century Plus Simulator Control Block, page 63
- Master Toggle – Century Plus Control Block Only, page 65
- Century Plus Simulator Control Block Manifold, page 64
- Handpiece Selector Valve, Two Handpiece, page 66
- Handpiece Selector Valve, Three Handpiece, page 67
- Foot Control Wet/Dry Toggle Valve, page 68
- Foot Control Valve Assembly, page 69
- Autoclavable Syringe, page 70
- Autoclavable HVE Standard Assembly, Central Vacuum, page 71
- Simulator Vacuum Generator Assembly, page 72
- AVS Valve Assembly, page 73
- Vacuum Canister/AVS Lid, page 74
- Torso Brake Parts, page 76
- Air Filter/Regulator and Water Filter/Regulator, page 78
- Air-actuated Water Shutoff Valve, page 80
- Button Valve, page 82
- Handpiece Holder Arms, page 84
- Tray Holder, page 85
- Headrest and Back Assembly, page 86
- 17 Watt Power Supply, page 91
- 25 Watt Power Supply, page 92
- 300 Watt Power Supply, page 94

Carriage Assembly, Standard Control Block

Item	Part Number	Description
1	39.1140.00	Carriage brake
2	83.0478.00	Clip (Mobile Simulators only)
3	042.521.00	Gas spring
4	001.065.00	Screw
5	002.094.02	Screw
6	026.109.00	Micro valve assembly (self-contained water only)
7	83.0141.00	Dual voltage intraoral light source assembly
8	39.1257.00	Two-handpiece selector valve
9	39.1195.00	Standard control block, two handpiece
10	39.1137.00	Cover, controls

Figure 35 Carriage Assembly, Standard Control Block

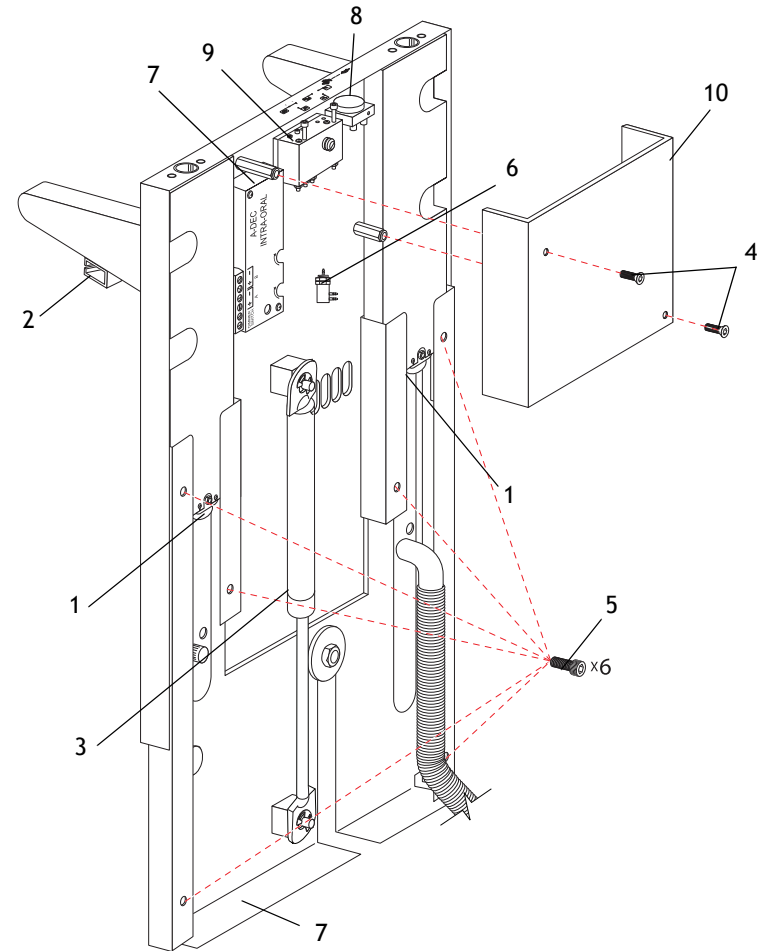

Carriage Assembly, Century Plus Control Block

Item	Part Number	Description
1	39.1140.00	Carriage brake
2	83.0478.00	Clip (Mobile Simulators only)
3	042.521.00	Gas spring
4	001.065.00	Screw
5	002.094.02	Screw
6	026.109.00	Micro valve assembly (self-contained water only)
7	83.0141.00	Dual voltage intraoral light source assembly
11	83.0516.00	Three-handpiece selector valve
12	38.0500.00	Block assembly, Century Plus, 2 HP
	38.0501.00	Block assembly, Century Plus, 3 HP
13	33.0048.05	Master toggle
14	83.0512.00	Cover, controls, upper
15	83.0513.00	Cover, controls, lower

Figure 36 Carriage Assembly, Century Plus Control Block

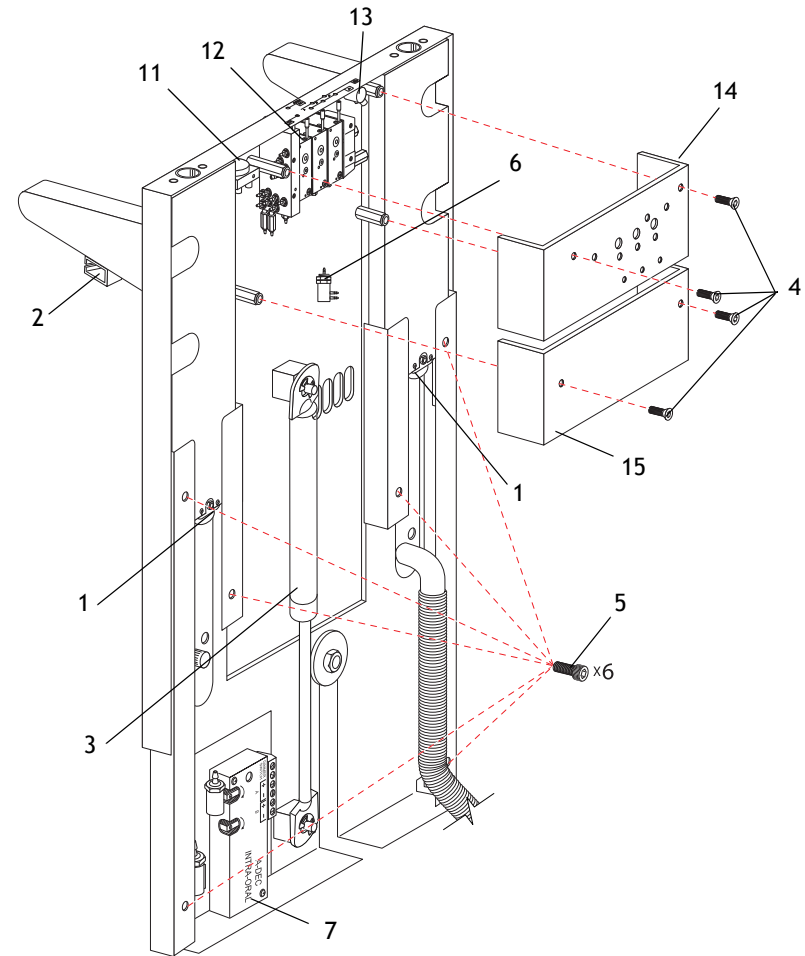

Standard Simulator Control Block Assembly, Two Handpiece

Part No: 39.1195.00

Item	Part Number	Description
1	29.0100.00	Flow control screw with O-ring
2	030.004.02	O-ring (package of 10)
3	39.1199.00*	Coolant air stem with O-ring
4	39.1345.00*	Coolant water stem with O-ring
5	39.1211.00*	Diaphragm
6	38.0717.00*	Water relay valve assembly
7	38.0718.00*	Water valve actuator
8	001.002.00*	Screw, truss head
9	001.021.00*	Screw, socket head
10	002.118.00*	Screw, button head socket
11	004.192.00*	Washer, flat

* These parts are included in the Control Block Kit (p/n 90.0469.00).

Figure 37 Standard Control Block Assembly, Two Handpiece

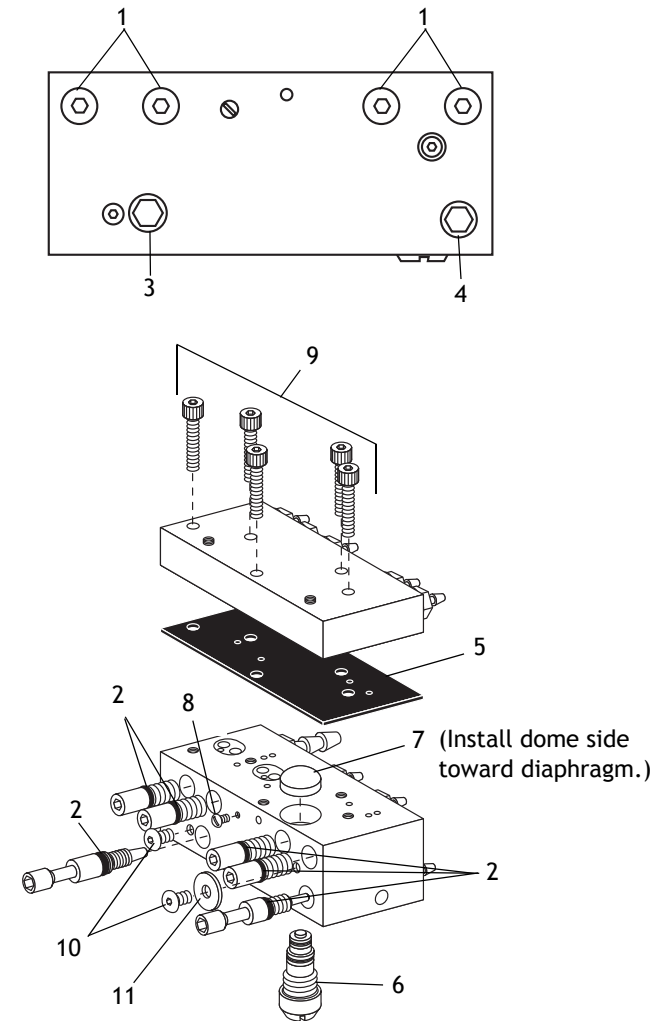

Century Plus Simulator Control Block Manifold

Part No: 38.0524.00

Item	Part Number	Description
1	38.0555.00	Syringe Flow Control Barb
2	013.072.00	Spring .21 OD X .71 long
3	034.001.01	O-ring (Package of 10)
4	035.033.01	O-ring (Package of 10)
5	38.0525.00	Flush Valve Stem with O rings
6	38.0526.00	Coolant Air Stem with O-ring
7	030.003.02	O-ring (Package of 10)

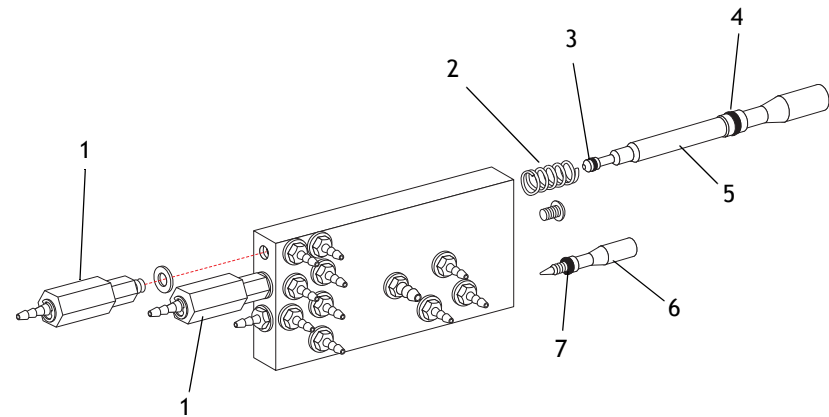

Master Toggle – Century Plus Control Block Only

Part No: 33.0048.05

Item	Part Number	Description
1	22.0462.02	Toggle, surf 4 with pin (fits flush with valve body)
2	29.0840.00	Stem with o-rings, 3-way
3	22.0040.00	Spring, .300 OD x .400 long
4	006.069.00*	Knurl nut

* This part is not included in the Master Toggle assembly (p/n 33.0048.05). Order it separately.

Figure 39 Master Toggle

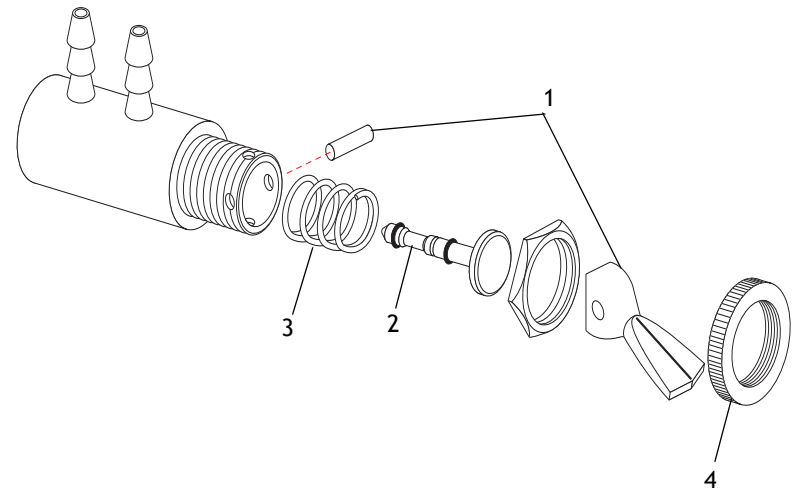

Handpiece Selector Valve, Two Handpiece

Part No: 39.1257.00

Item	Part Number	Description
1	004.005.02	Nylon washer (package of 10)
2	010.047.00	Retaining ring
3	013.104.00	Spring
4	015.022.00	Ball bearing
5	023.004.03	Barb, 1/8"(package of 10)
6	030.001.02	O-rings (package of 10)

Figure 40 Selector Valve, Two Handpiece

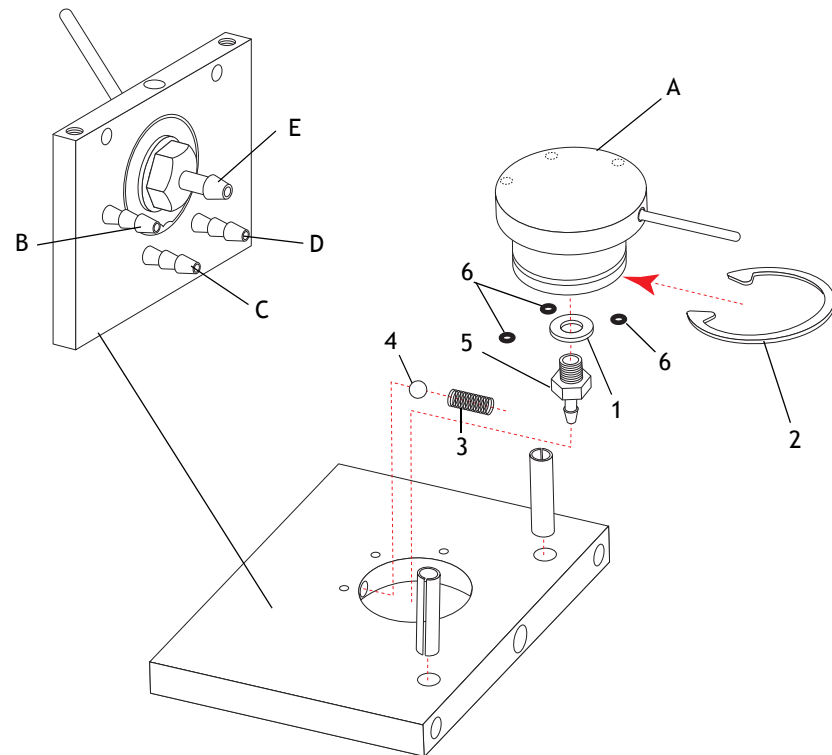

(A) Selector Knob; Lube selector knob with Lubriplate lube periodically to prevent sticking; (B) High Speed Handpiece; (C) Low Speed Handpiece
 (D) Pilot Air Out; (E) Master Air In

Handpiece Selector Valve, Three Handpiece

Part No: 83.0516.00

Item	Part Number	Description
1	004.005.02	Nylon washer (package of 10)
2	010.047.00	Retaining ring
3	013.104.00	Spring
4	015.022.00	Ball bearing
5	023.004.03	Barb, 1/8" (package of 10)
6	030.001.02	O-rings (package of 10)

Figure 41 Selector Valve, Three Handpiece

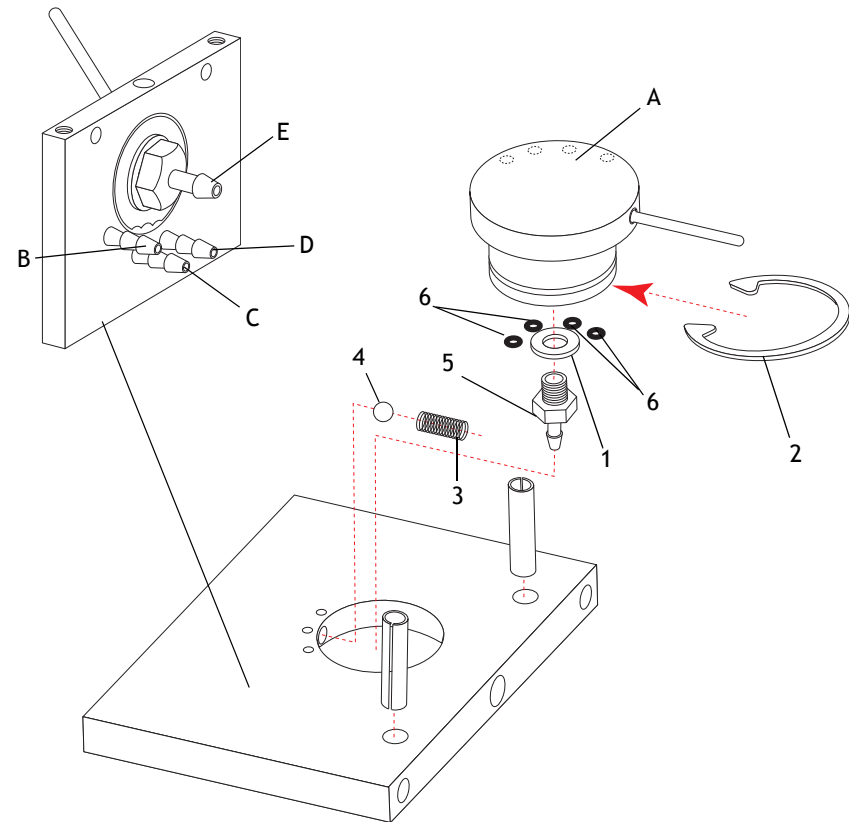

(A) Selector Knob; Lube selector knob with Lubriplate lube periodically to prevent sticking; (B) Handpiece 1; (C) Handpiece 2; (D) Handpiece 3; (E) Pilot Air In

Foot Control Wet/Dry Toggle Valve

Part No: 38.0604.00

Item	Part Number	Description
1	38.0075.03	Foot control toggle valve lever, with pin, pur, Surf 6
2	38.0066.00	Cap spring, wet/dry valve assembly
3	22.0040.00	Spring, helical compression, .300 OD x .40
4	010.056.00	Retainer spring, .600 diameter
5	38.0072.03	Holder valve, Surf 6
6	011.016.00	Pin, dowel, .125 diameter x .625
7	007.021.00	Setscrew, socket cup point, 6-32 x 3/16
8	33.0138.00	3-way micro valve assembly

Figure 42 Foot Control Wet/Dry Toggle Valve

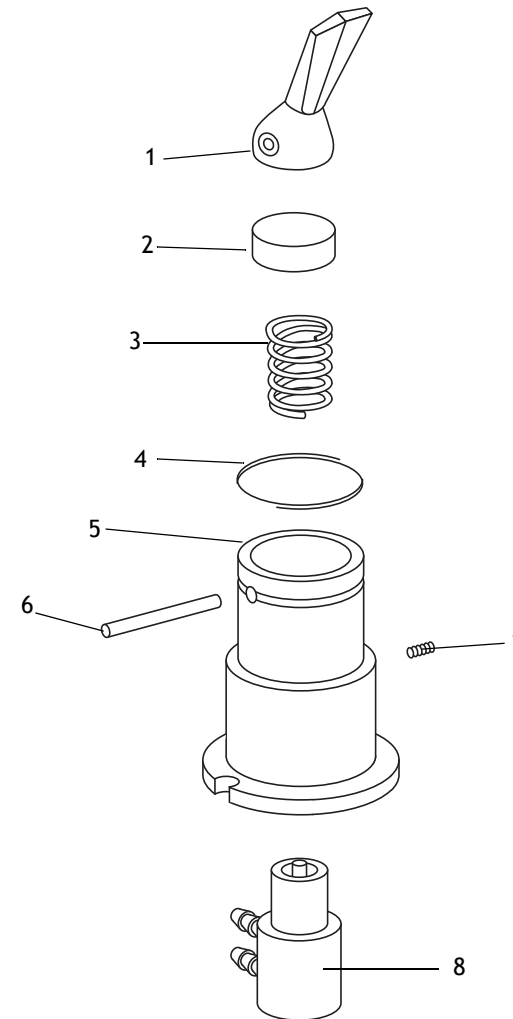

Foot Control Valve Assembly

Part No: 38.0761.00

Item	Part Number	Description
1	003.078.00	Socket head screw
2	10.0440.00*	Spring
3	013.011.00*	Spring, helical compression
4	030.012.02*	O-ring (package of 10)
5	22.0050.00	Spring cap
6	22.0060.00*	Poppet
7	22.0580.00*	Spring
8	22.0778.00*	Stem with o-rings
9	38.0054.02*	Diaphragm (package of 10)
10	38.0056.00	Signal relay valve
11	38.0760.00*	FC3 piston

* These parts are included in the Foot Control III Service Kit (part number 90.0593.00).

Figure 43 Foot Control III Valve Assembly

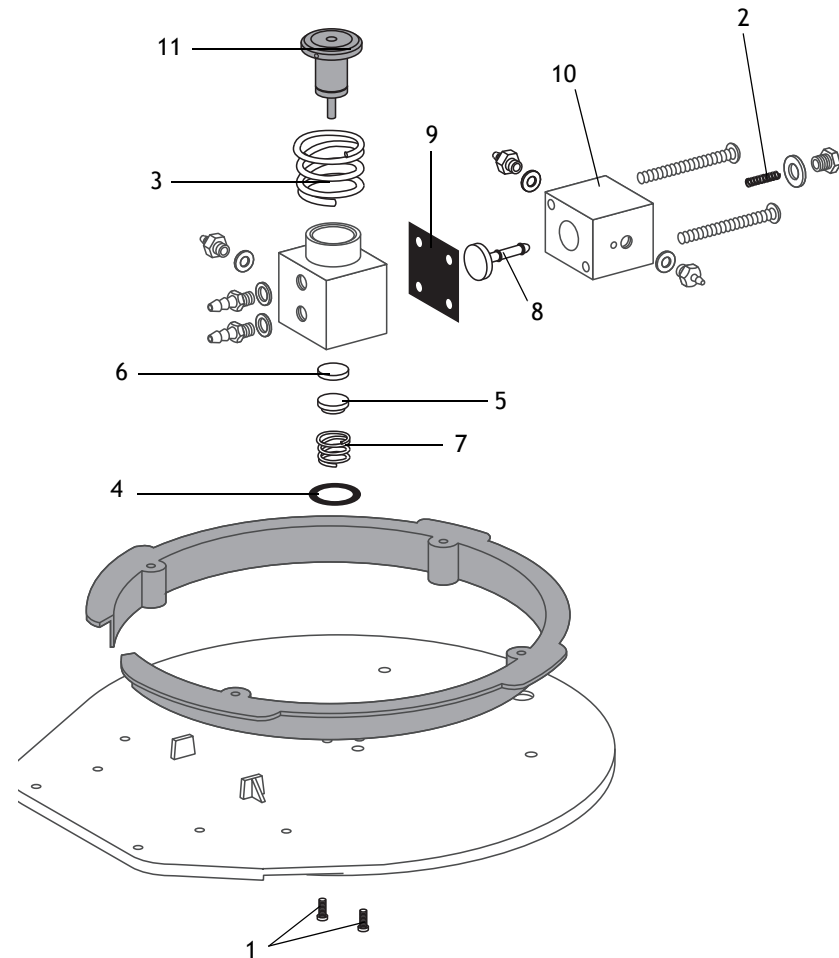

Autoclavable Syringe

Part No: 23.1150.00

Item	Part Number	Description
1	23.1112.00	Nut assembly, syringe, smooth, with O-rings
2	23.1190.00	Syringe, Traditional, autoclavable, assembly, with 7'
3	23.1101.01	Spacer, syringe nut, with O-ring
4	030.002.02	O-ring, package of 10
5	23.1015.00	Syringe handle, for ambient (cold) water
6	23.1208.00	assembly, D-Surf, 7'
7	23.1193.01	Screw, 2-56, package of 5
8	23.1232.01	Valve, assembly button, autoclavable, package of 2
9	013.064.01	Spring, compression, conical, package of 10
10	23.1110.00	Terminal, 2 barb assembly, No-Quick Disconnect
11	035.048.01	O-ring, E, .114 ID x .07 W, package of 10
12	034.003.01	O-ring, E, .056 ID x .060 W, package of 10
13	23.0872.01	Syringe tip, package of 5

Figure 44 Autoclavable Syringe

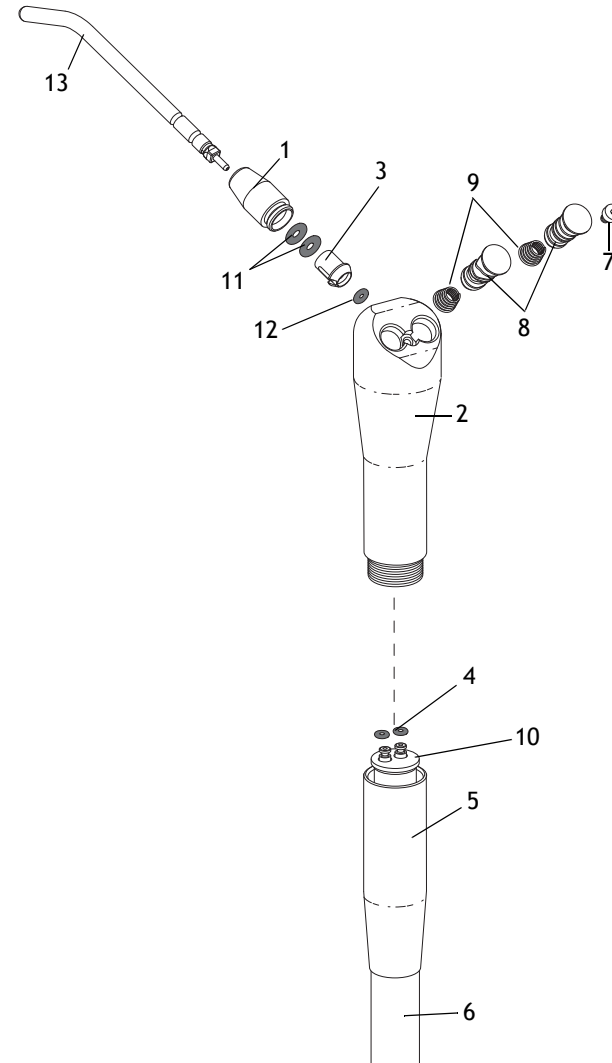

Autoclavable HVE Standard Assembly, Central Vacuum

Part No: 11.1296.00

Item	Part Number	Description
1	11.1071.00	Body, autoclavable HVE
2	11.1274.00	Rotor assembly with O-rings
3	11.0998.01	Screen, spring clip, QD, HVE, package of 5
4	034.014.01	O-ring, E, .489 ID x .070 W, package of 10
5	034.013.01	O-ring, E, .426 ID x .070 W, package of 10
6	034.018.02	O-ring, .739 ID x .070 W, package of 10
7	11.1027.00	Tailpiece, QD, short, Surf 6
8	024.144.03	, 1/2 ID, 10'
9	11.1300.01	Tailpiece, standard HVE, with O-ring
10	034.018.02	O-ring, .739 ID x .070 W, package of 10
11	12.1237.00	Standard HVE assembly, over the counter

Figure 45 Autoclavable HVE Assembly

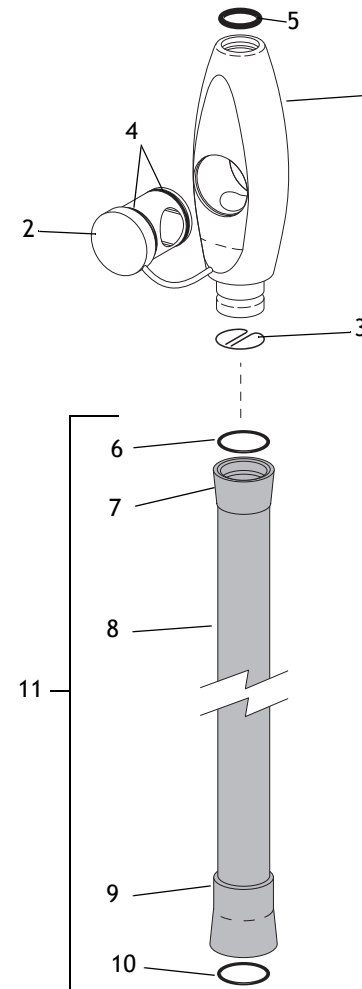

Simulator Vacuum Generator Assembly

Part No: 11.1083.00

This assembly is only available on units with the Simulator AVS.

Item	Part Number	Description
1	001.021.00	Screw, socket head
2	001.042.00	Screw, socket head
3	004.005.02	Nylon washer (package of 10)
5	023.083.00	Retainer 1/8"
6	023.084.00	Male QD barb 1/8"
7	023.087.00	Retainer 1/4"
8	023.088.00	Male QD barb 1/4" with O-ring
9	023.089.00	Female QD 1/8", 10-32
10	023.090.00	Female QD 1/4", 10-32
11	030.012.02	O-ring (package of 10)
12	11.1084.00	Body
13	11.1085.00	Jet, vacuum
14	11.1086.00	Valve cover
15	22.0440.02	Diaphragm (package of 10)
16	38.0517.00	Air cartridge
	38.0735.00	Optional air cartridge with larger orifice
17	41.0515.00	Spacer
18	41.0516.00	Stepped piston

Figure 46 Vacuum Generator Assembly (only on units with Simulator AVS)

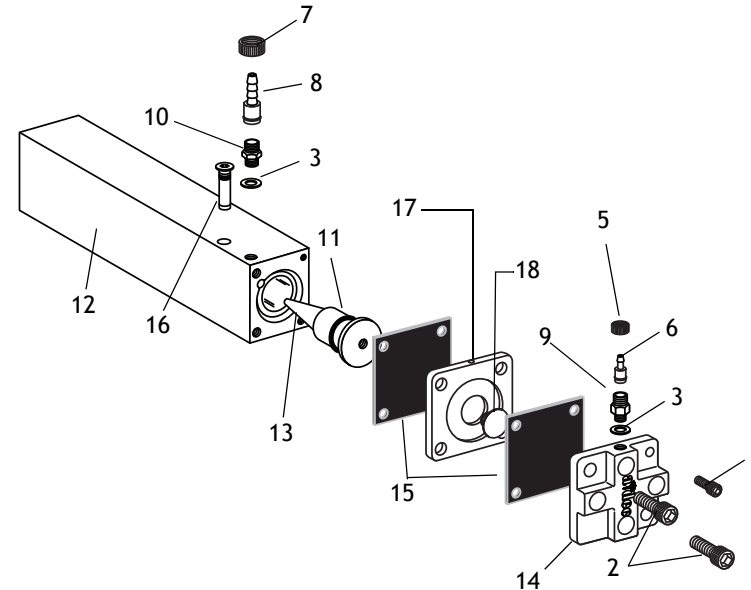

AVS Valve Assembly

Part No: 11.1127.00

Item	Part Number	Description
1	007.002.01	Setscrew, socket cup point (package of 10)
2	024.162.01	(10 ft. length)
3	030.002.02	O-rings (package of 10)
4	030.013.02	O-ring (package of 10)
5	035.049.01	O-ring (package of 10)
6	036.003.03	(10 ft. length)
7	11.1135.00	Retainer
8	11.1128.00	Rotor
9	11.1129.00	AVS body assembly

Figure 47 AVS Valve Assembly (PN 11.1127.00)

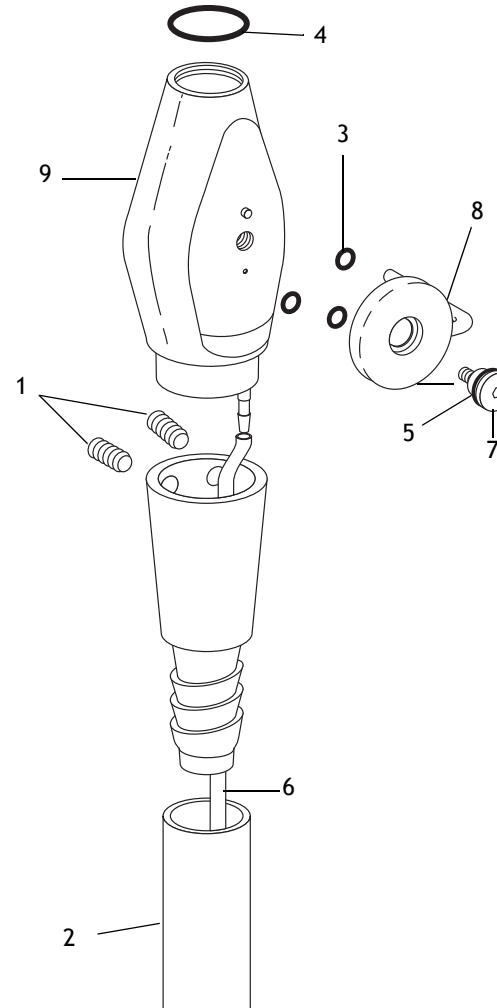

Vacuum Canister/AVS Lid

Part No: Drain Valve Assembly Kit (90.1030.00)

Item	Part Number	Description
1	12.0182.00	Valve stem with O-rings
2	030.010.02	O-rings (package of 10)
3	83.0290.00	Drain body
4	83.0292.00	Washer

Part No: Vacuum Canister Assembly (83.0136.00)

Item	Part Number	Description
5	030.016.02	O-ring (package of 10)
6	030.030.02	O-ring (package of 10)
7	75.0035.01	Vacuum screen (package of 5)
8	034.014.01	O-ring (package of 10)
9	83.0185.00	HVE cap assembly
10	83.0186.00	Body, HVE canister

Part No: Vacuum Canister, AVS (83.0137.00)

Item	Part Number	Description
11	030.228.02	O-ring (package of 10)
12	007.002.01	Setscrew (package of 10)
13	030.016.00	O-ring
14	052.003.00	Bottle
15	11.1079.00	Mounting block
16	11.1078.00	Vacuum canister
17	004.005.02	Nylon washer (package of 10)
18	023.004.03	Barb, 1/8" (package of 10)

Figure 48 Vacuum Canisters

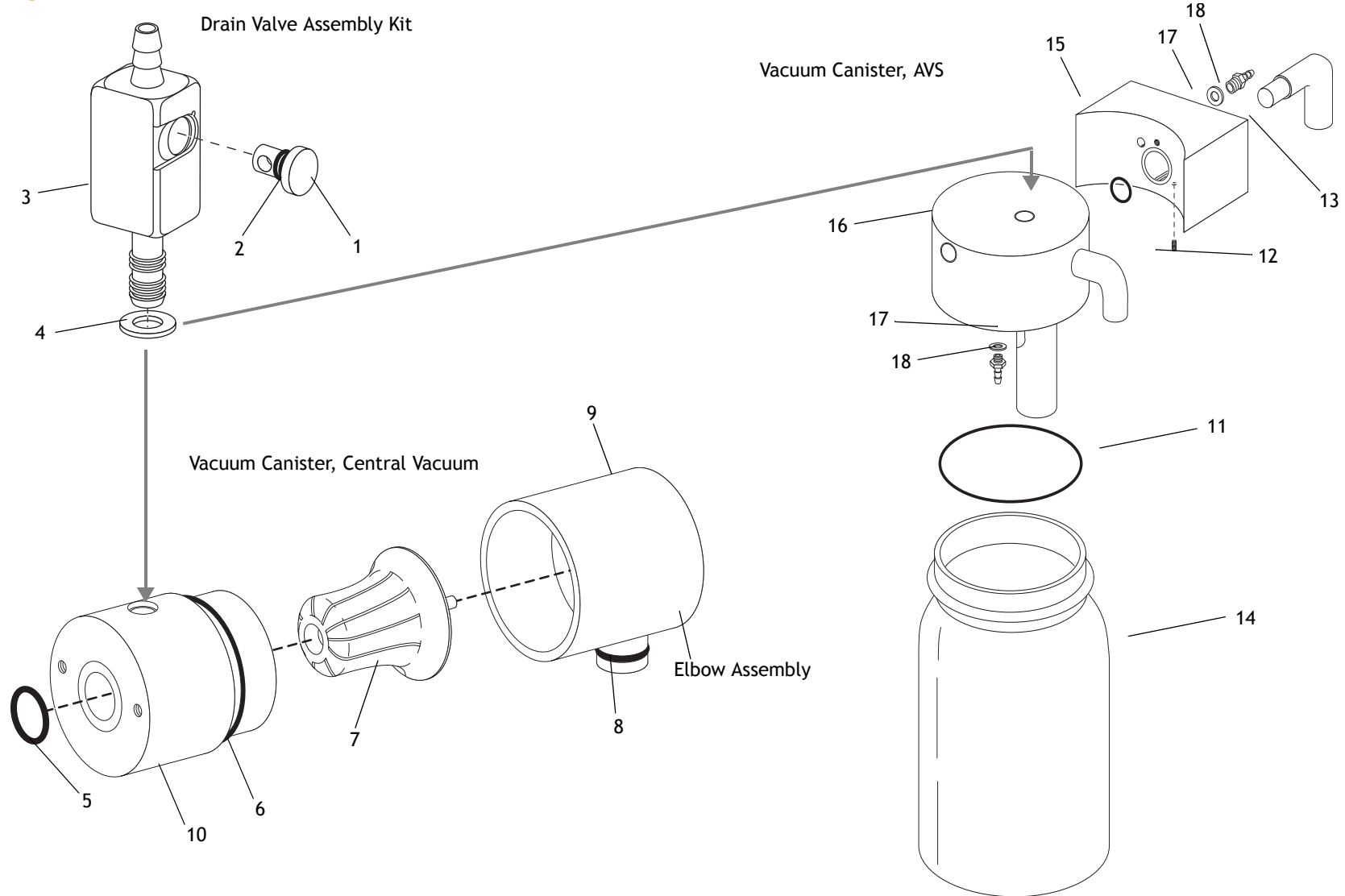

Torso Brake Parts**Part No: 83.0193.00**

Item	Part Number	Description
1	001.085.00	Screw socket head
2	001.088.00	Screw, socket head
3	004.005.02	Nylon washer (package of 10)
4	006.022.00	Hex nut
5	007.024.00	Setscrew
6	007.047.00	Setscrew
7	010.066.00	Retaining ring
8	011.111.00	Pin
9	013.103.00	Spring
10	004.113.00	Lock washer
11	015.022.00	Ball bearing
12	023.070.00	Barb, Restrictor
13	39.1204.00	Cylinder end, rotary brake, front
14	39.1205.00	Cylinder end, rotary brake, back
15	39.1206.00	Piston
16	39.1208.00	Diaphragm
17	39.1346.00	Modified setscrews
18	83.0196.00	Adjuster spring
19	83.0197.00	Eccentric Pin
20	83.0198.00	Plunger
21	83.0200.00	Standoff
22	83.0199.00	Link
23	83.0201.00	Pin

Figure 49 Torso Brake Assembly

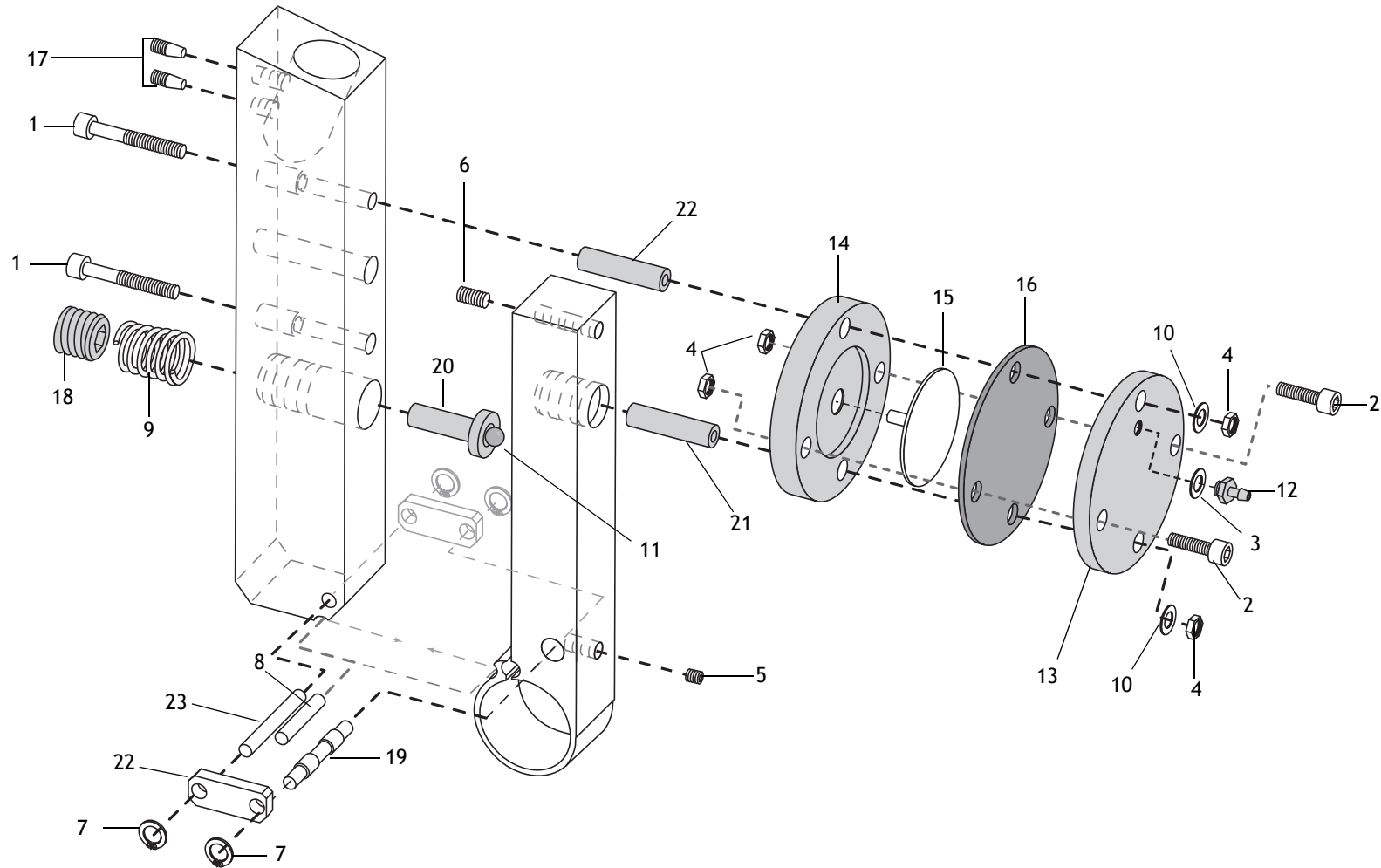

Cross-System Features

Air Filter/Regulator and Water Filter/Regulator

Common parts to both assemblies:

Item	Part Number	Description
1	001.026.00	Screw, socket head
5	023.001.03	Barb 1/4" (package of 10)
6	030.019.03	O-ring (package of 10)
7	24.0137.01	Gasket (package of 10)
8	24.0229.00	Filter housing
9	24.0232.00	Stud
10	24.0234.01	Filter element (package of 6)
14	001.024.00	Socket head screw
15	004.005.02	Washer (package of 10)
16	030.003.02	O-ring (package of 10)
17	22.0440.02	Diaphragm (package of 10)
19	24.0132.00	Piston with O-ring
20	023.004.03	Barb 1/8" (package of 10)

Part No: 83.0205.00 (Air Filter/Regulator Assembly Only)

Item	Part Number	Description
3	022.014.01	Nut with sleeve, 3/8"
4	023.001.03	Barb, 1/4"
11	24.0366.00	Regulator assembly, air
12	24.0382.00	Regulator assembly, preset
13	80.5303.02	Regulator assembly, relieving
18	22.0460.00	Spring, conical (air regulator only)
27	022.065.00	Adapter, 3/8" poly
29	24.0135.00	Body, regulator, white

Part No: 83.0210.00 (Water Filter/Regulator Assembly Only)

Item	Part Number	Description
21	022.060.01	Adapter, 1/4" poly
22	013.032.00	Spring, conical (for water regulator assembly only)
23	021.010.00	Pipe plug
24	021.016.04	Plug (package of 10)
25	021.029.00	Reducer
26	24.0367.00	Regulator assembly, water
28	022.029.01	Nut with sleeve, 1/4"
30	24.0355.00	Body, regulator, black

Figure 50 Air Filter/Regulator and Water Filter/Regulator

Air Regulator Assembly (83.0205.00)

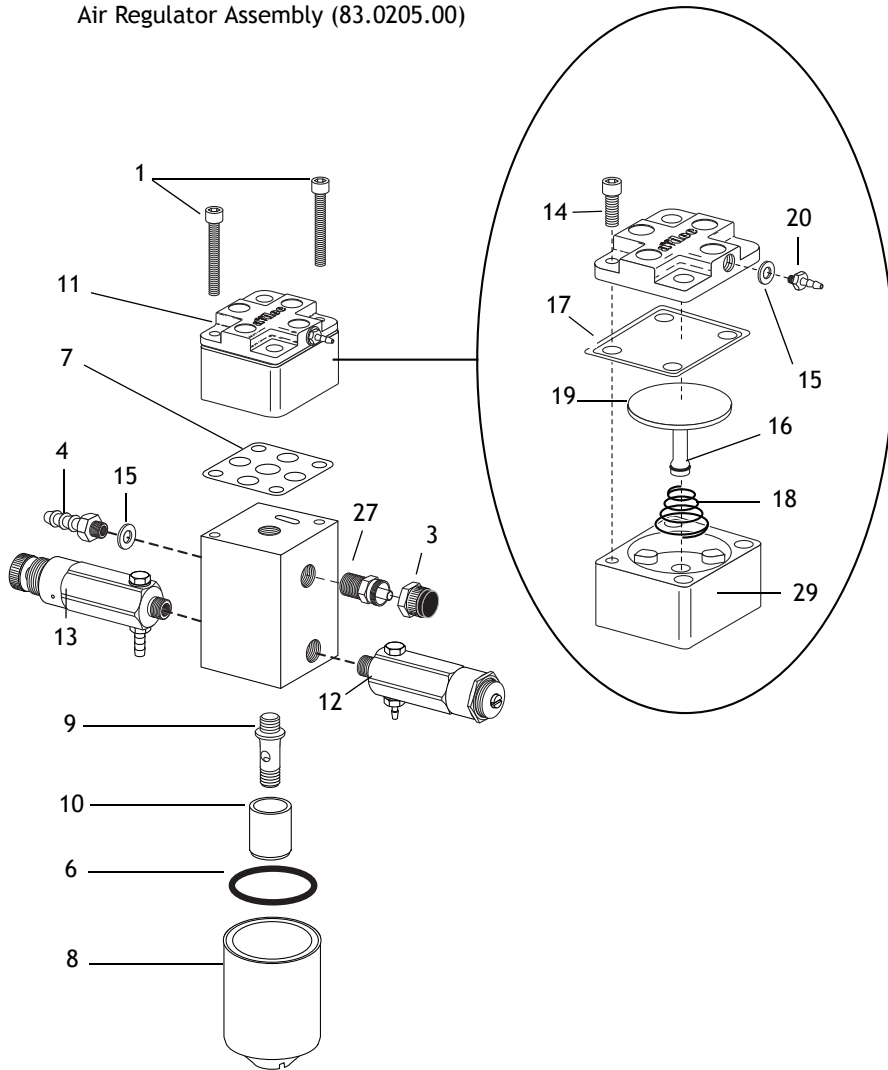

Water Regulator Assembly (83.0210.00)

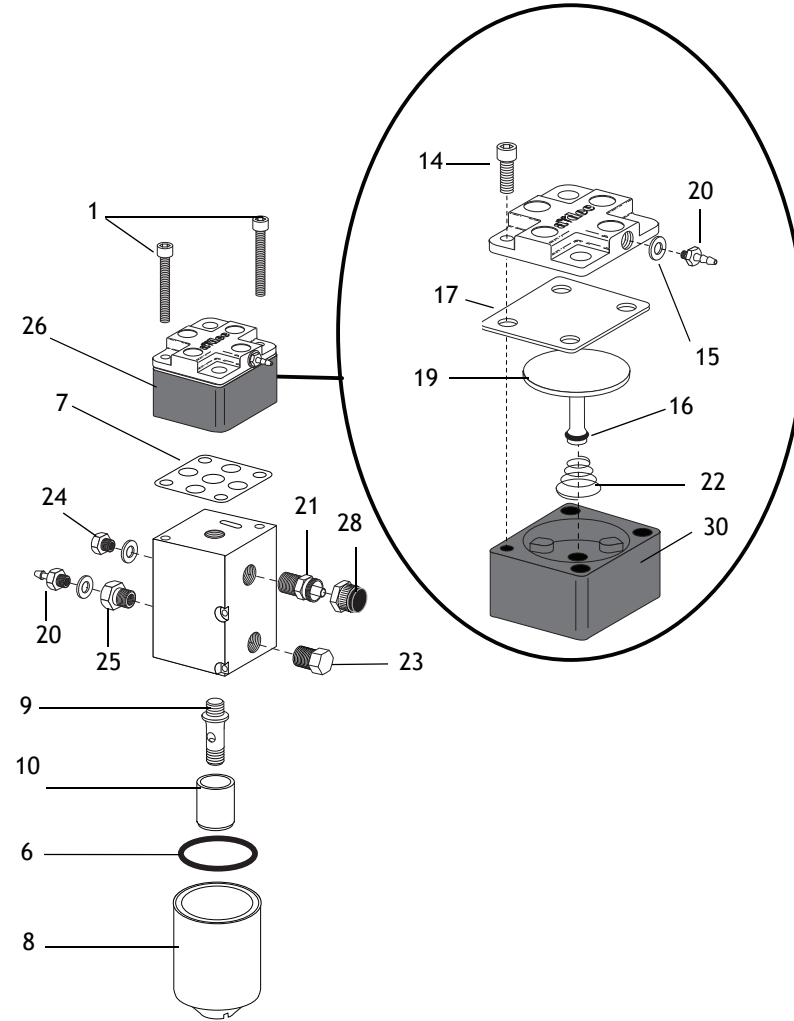

Cross-System
 Features

Air-actuated Water Shutoff Valve

Part No: 83.0314.00 (Threaded Shut-off Valve)

Item	Part Number	Description
1	001.026.00	Socket head screw
2	021.004.00	Nipple
3	022.029.01	Nut with sleeve
4	022.060.01	Adapter, 1/4 poly
5	24.0137.01	Gasket (package of 10)
6	24.0367.00	Regulator assembly, water

Part No: 34.0032.00 (Compression Shut-off Valve)

Item	Part Number	Description
1	001.026.00	Socket head screw
2	021.042.00	Adaptor
3	022.029.01	Nut with sleeve
4	022.060.01	Adaptor
5	24.0137.01	Gasket (package of 10)
6	24.0367.00	Regulator assembly, water

Figure 51 Air-actuated Water Shutoff Valves

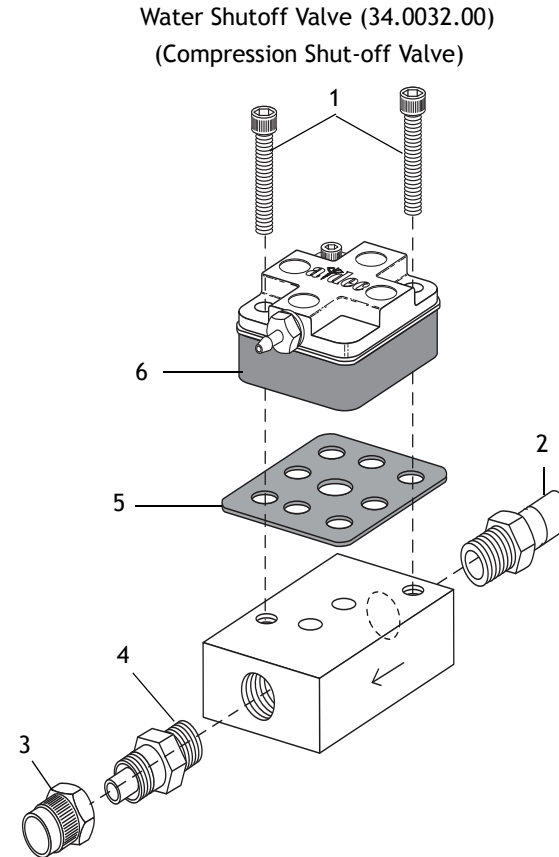
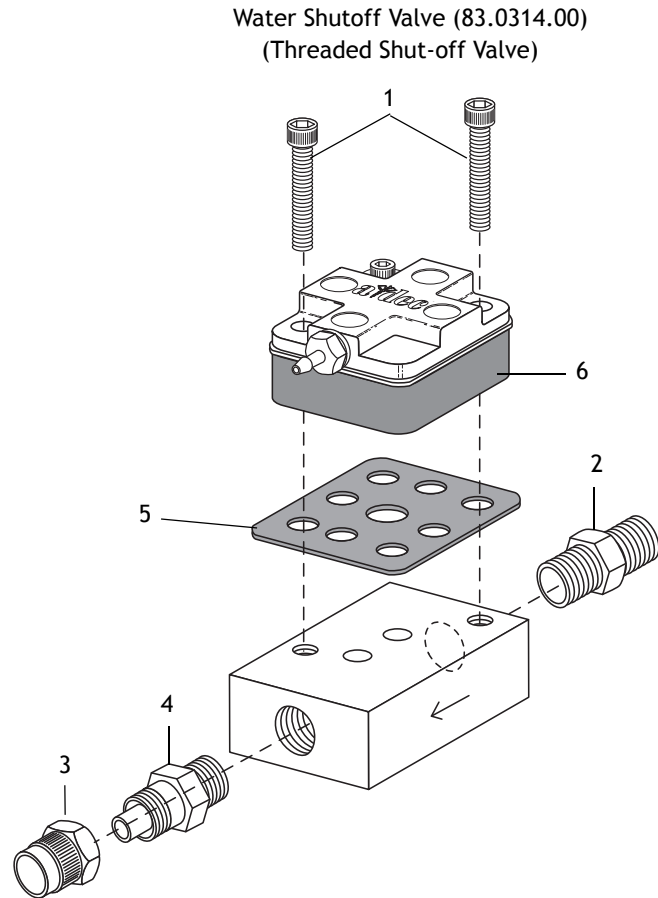

Button Valve

Button Valve Prior to November, 2001

Order retrofit upgrade kit F84J.001 for complete assembly.

Item	Part Number	Description
1	006.006.00	Locknut
2	007.010.00	Setscrew
3	12.0922.00	Actuator button
4	12.0928.00	Plunger
5	33.0138.00	3-way valve
6	39.1181.00	Bezel

Button Valve After November 2001

Part No: F84J.001*

Item	Part Number	Description
1	006.009.00	Nut, hex
2	011.082.00	Pin, clip
3	12.1028.00	Actuator assembly
4	33.0138.00	3-way valve

* This assembly does not include the 3-way valve (part number 33.0138.00).

Figure 52 Button Valve, Brake Actuation, Torso Lift and Rotation

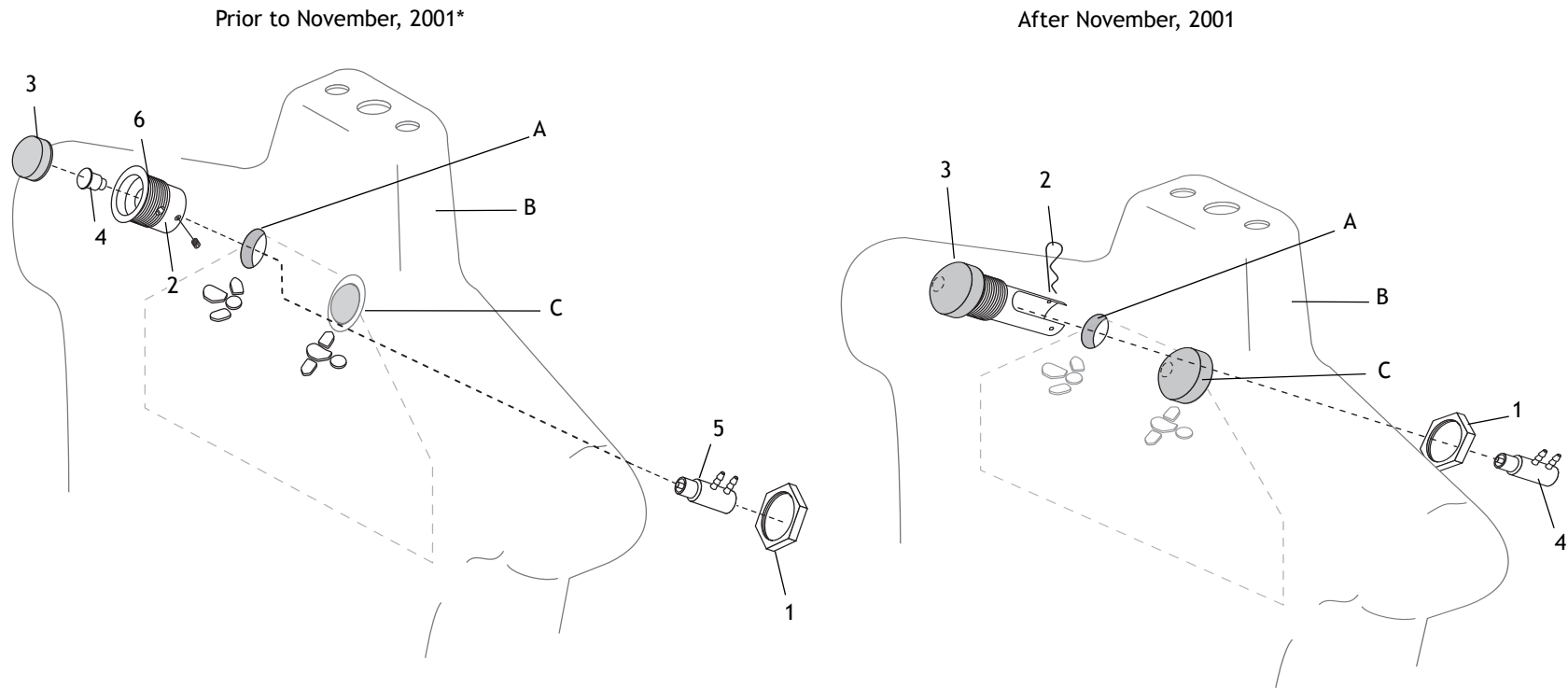

(A) Torso Rotation Button; (B) Simulator Torso; (C) Carriage Lift Button

*Retrofit kit available. Order F84J.001 upgrade kit, which includes both buttons.

Handpiece Holder Arms

Part No: 83.0133.00 (2 Position) and 83.0134.00 (3 Position)

Item	Part Number	Description
1	001.093.02	Socket head patch screw
2	35.1027.02	Tray washer
3	016.053.00	Thrust washer
4	016.054.00	Thrust needle bearing
5	004.117.00	Flat washer
6	024.092.00	Clear
7	83.0180.00	Control arm (order with clear installed)
8	-	Two position holder bar (order as a special only)
9	-	Three position holder bar (order as a special only)
10	007.004.00	Socket cup set screw
11	005.109.00	Socket screw, button head
12	12.0848.01	Assistant's holder adaptor
13	004.170.00	Flat washer
14	12.1009.00	Arm pin pivot

* These parts are included as part of an assembly.

Figure 53 Handpiece Holder Arms

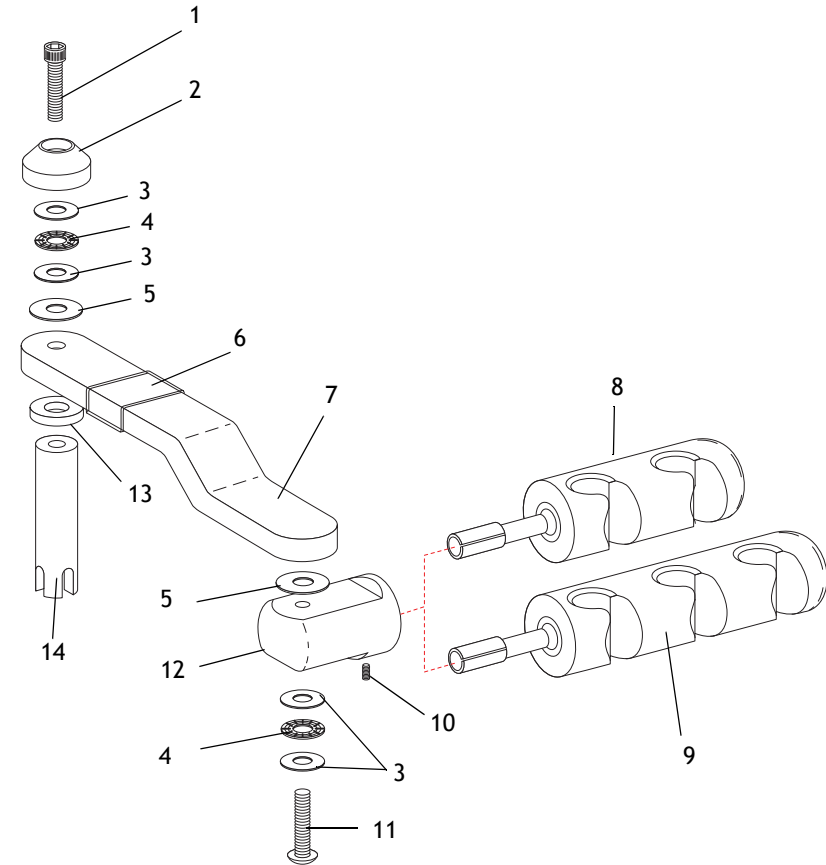

Tray Holder

The tray holder is an optional feature.

Part No: 83.0306.00

Item	Part Number	Description
1	83.0308.00	Tray Holder
2	002.115.00	Hex screw
3	004.019.00	Spring washer
4	004.172.00	Thrust washer
5	001.016.01	Screw
6	016.102.00	Thrust needle bearing
7	47.1372.00	Bearing mount
8	004.054.00	Flat washer
9	83.0307.00	Tray holder arm
10	016.054.00	Thrust needle bearing
11	001.093.01	Socket head screw
12	35.1027.02	Tray washer
13	016.053.00	Thrust washer
14	004.117.00	Flat washer
15	004.170.00	Flat washer
16	12.1009.00	Pivot

Figure 54 Optional Tray Holder

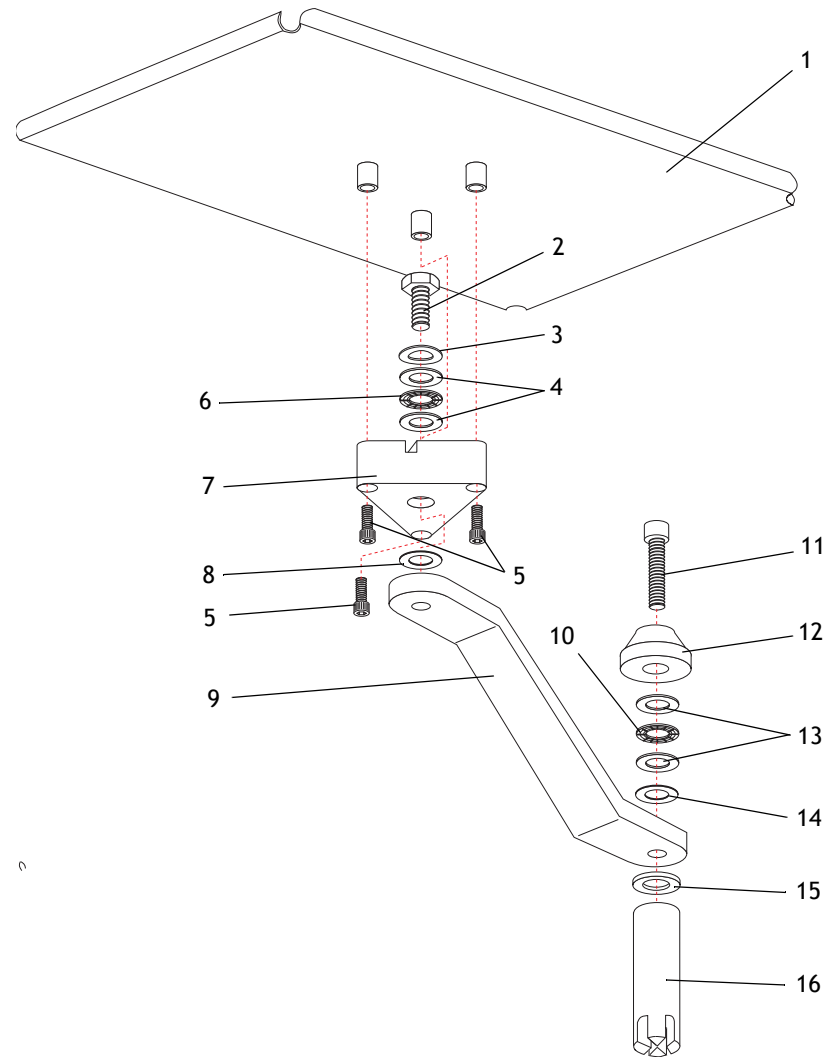

Headrest and Back Assembly

The headrest is an optional feature.

Part No: 83.0409.00

Item	Part Number	Description
1	83.0410.00	Headrest assembly
2	004.138.00	Lock washer (2)
3	005.109.00	Socket screw, button head (2)
4	83.0392.00	Chair back
5	005.088.00	Socket head screw (4)
6	83.0411.00	Washer (4)
7	83.0414.00	Brake plate
8	83.0413.00	Brake shoe
9	83.0412.00	Spacer (2)

Figure 55 Optional Headrest and Back Assembly

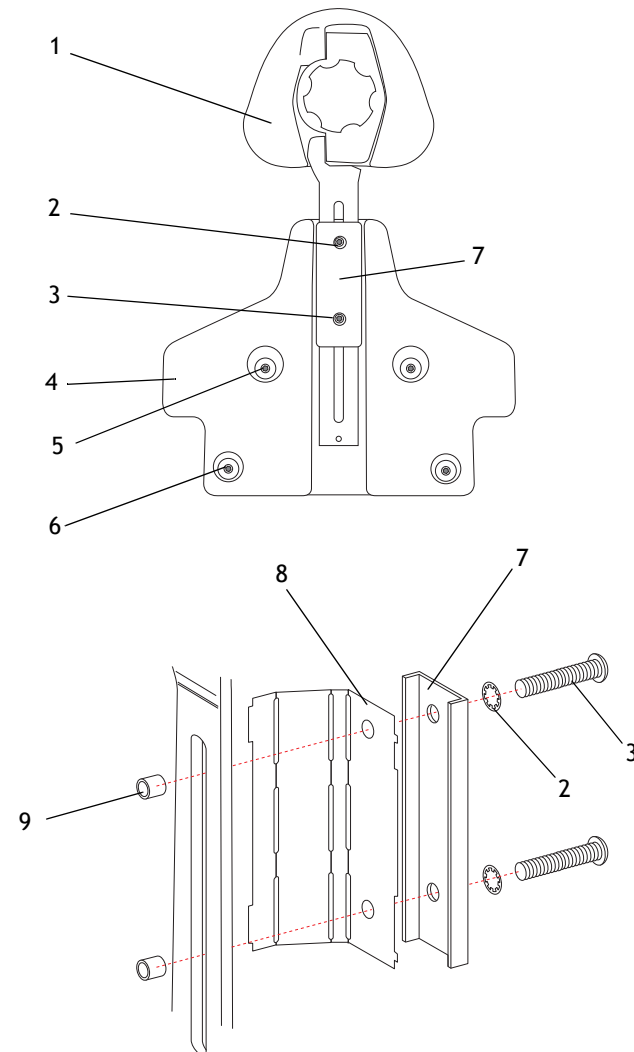

Double Articulating Headrest

Part No: **83.0410.00**

Item	Part Number	Description
1	001.157.00	Screws
2	83.0415.00	Glide bar assembly
3	010.024.00	Retaining rings

Upholstery Options

Item	Part Number	Description
4	61.2116.xx	Double-articulating headrest formed upholstery
	61.2617.xx	Double-articulating headrest plus upholstery

Figure 56 Optional Headrest and Back Assembly

Double-Articulating Headrest Assembly

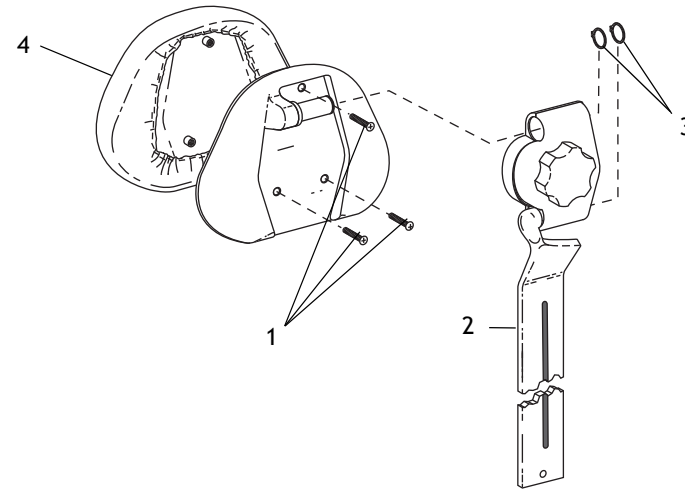

Third Hand Kit

The third hand kit is an optional feature.

Part No: 83.0479.00

Item	Part Number	Description
1	83.0480.00	Flex tube, 10"
2	004.054.00	Washer, plastic
3	004.213.00	Washer, 2.5" OD
4	004.172.00	Washer, thrust
5	016.102.00	Thrust bearing
6	83.0483.00	Swivel
7	004.019.00	Spring washer
8	003.055.00	Screw
9	007.069.00	Setscrew
10	028.014.02	Plug
11	002.135.00	Screw
12	004.212.00	Washer, plastic
13	83.0482.00	Adaptor
14	016.053.00	Washer, thrust
15	004.162.00	Spring washer
16	001.093.02	Screw
17	016.054.00	Bearing
18	007.021.00	Setscrew
19	011.120.00	Pin
20	002.082.03	Screw
21	027.021.00	Knob
22	83.0481.00	Clamp body

17 Watt Power Supply

There are no serviceable parts in the power supply. Replace it with a 25 watt assembly (see page 92). Power supply does not include power cord.

Item	Part Number	Description
1	041.628.00	110V power cord
2	041.552.00	240V power cord
3	83.0317.00	Simulator wiring harness for Mobile Simulator
3	83.0312.00	Simulator wiring harness for Stationary Simulator
4	†	17 Watt power supply

†Part is not for sale.

Figure 58 17 Watt Power Supply, 115V and 230V

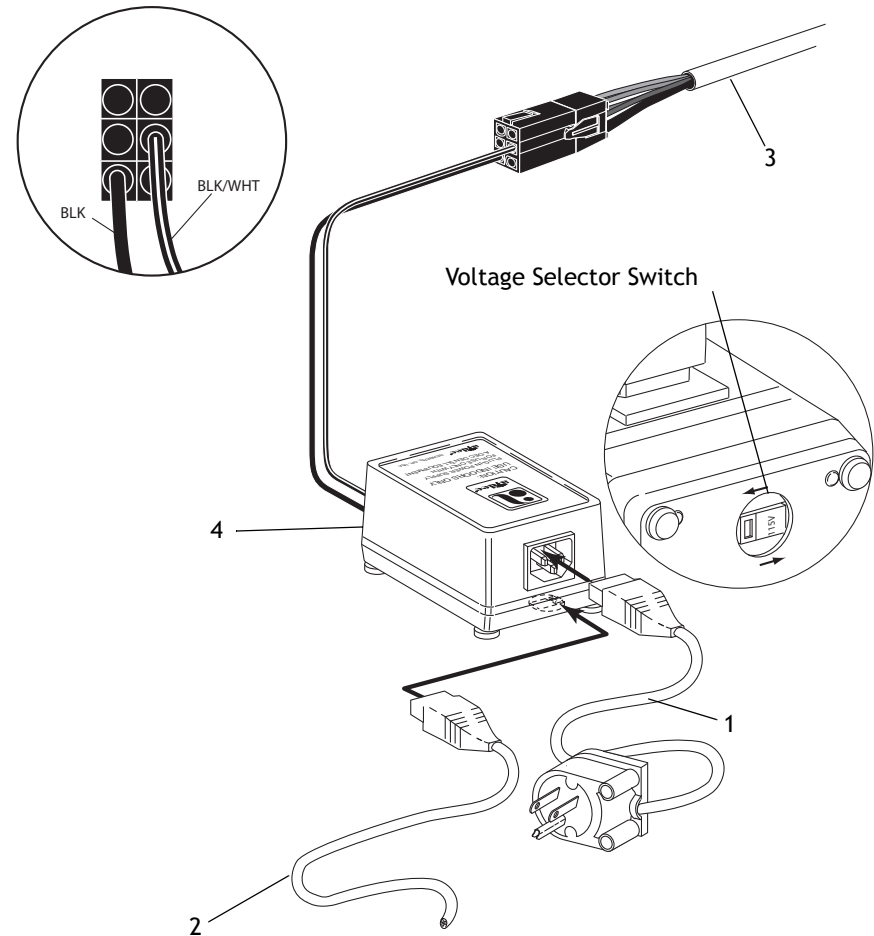

25 Watt Power Supply

Table 11 25 Watt Power Supply Part Numbers

Voltage	With Air/Electric Switch	Without Air/Electric Switch
100 V	28.1479.00	83.0475.00
110-120V	28.1480.00	83.0476.00
220-240V	28.1481.00	83.0477.00

Table 12 White 6-pin Connector (Dental Light)

Pin	Voltage	Wire
1		
2	0 Vac	Black
3		
4		
5		
6	12.1 Vac	Gray

Table 13 Black 6-pin connector (Handpiece Control)

Pin	Voltage	Wire
1	Ground	Green/Yellow
2	0 Vac	Black
3		
4		
5		
6	24 Vac	Yellow

Figure 59 25 Watt Power Supply Cable and Connectors

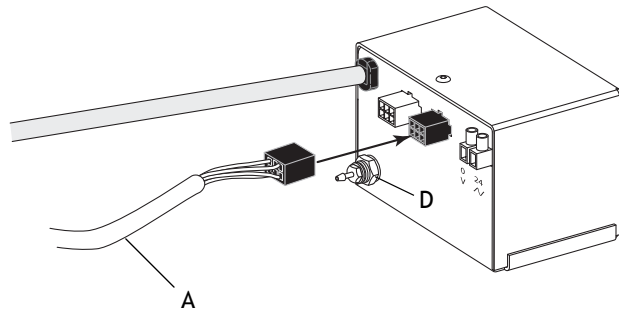

Figure 60 100 and 110-120 Vac Power Supply Plumbing (When Air Electric Switch is Provided)

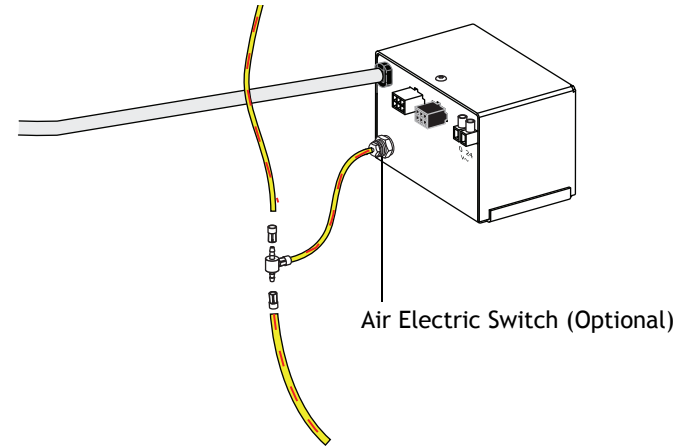
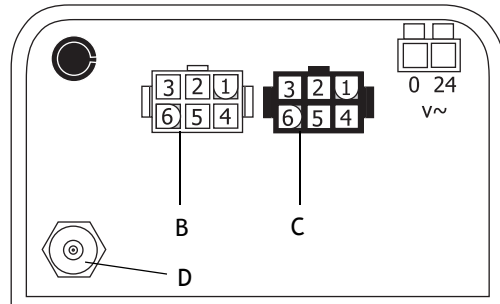
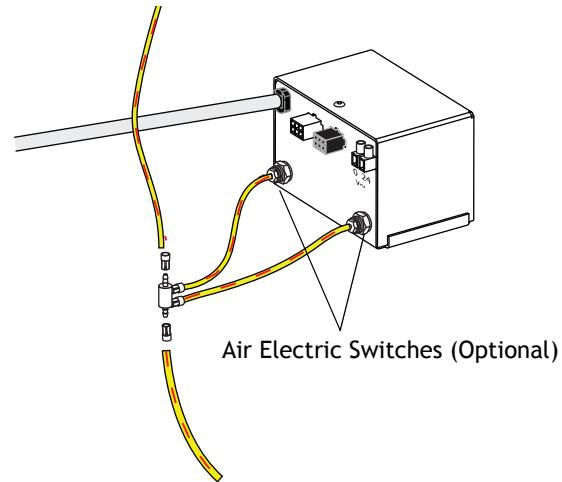

Figure 61 220-240 Vac Power Supply Plumbing (When Air Electric Switch is Provided)



(A) Handpiece Control Cable; (B) White 6-pin Connector; (C) Black 6-pin Connector; (D) Air Electric Switch

300 Watt Power Supply

Table 14 300 Watt Power Supply Part Numbers

Voltage	With Air/Electric Switch	Without Air/Electric Switch
100 V	28.1434.00	83.0528100
110-120V	28.1435.00	83.0502.00
220-240V	28.1436.00	83.0529.00

Table 15 Black 4-pin Connector (Optional Call Light)

Pin	Voltage	Wire
1	0 Vac	Black/White (switched)
3	24 Vac	Gray
4	6 Vac	Red

Table 16 Black 6-pin Connector (Handpiece Control)

Pin	Voltage	Wire
1	Ground	Green/Yellow
2	0 Vac	Black/White
3	0 Vac	Black/White
4	6 Vac	Red
5	17 Vac	Violet
6	24 Vac	Gray

Table 17 Red 6-pin Connector (Dental Light)

Pin	Voltage	Wire
1	Ground	Green/Yellow
2	0 Vac	Black/White
3	15 Vac	Green
4	16 Vac	Blue
5	17 Vac	Violet
6	10.8/12.1 Vac	White

Table 18 White 6-pin Connector

Pin	Voltage	Wire
1	Ground	Green/Yellow
2	0 Vac	Black
3	10.8/12.1 Vac	White
4	10.8 Vac	Orange
5	12.1 Vac	Yellow
6	12.1 Vac	Yellow

Figure 62 300 Watt Power Supplies

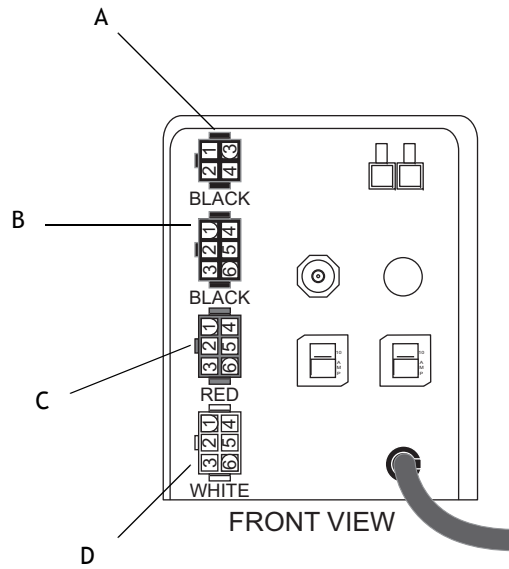

- (A) Black 4-pin Connector (Optional Call Light);
- (B) Black 6-pin Connector (Handpiece Control);
- (C) Red 6-pin Connector (Dental Light);
- (D) White 6-pin Connector

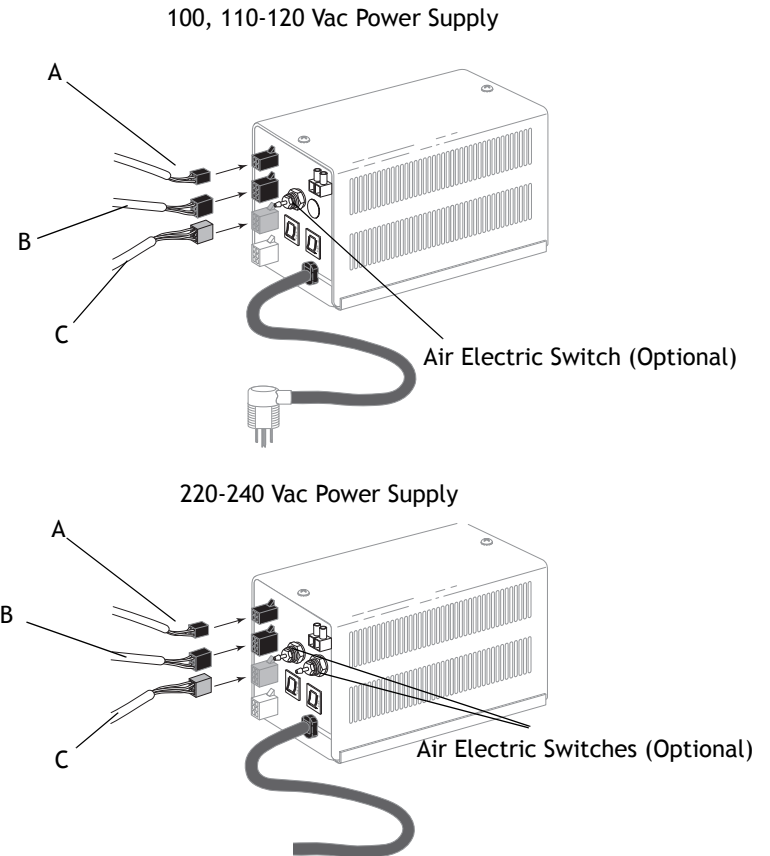

- (A) Optional Call Light Cable;
- (B) Handpiece Control Cable;
- (C) Dental Light Cable



TROUBLESHOOTING

This section covers troubleshooting information for the Simulator. These tables are not intended to cover every situation, but they do include the most common problems that may be encountered.

TROUBLESHOOTING CONTENTS

- Troubleshooting the Carriage Assembly, page 12
- Troubleshooting the Standard Simulator Control Block, page 14
- Troubleshooting the Century Plus Control Block, page 15
- Troubleshooting the Foot Control, page 24
- Troubleshooting the Autoclavable Syringe, page 27
- Troubleshooting the HVE Valve, Central Vacuum, page 28
- Troubleshooting the Air Vacuum System (AVS), page 29
- Troubleshooting the Torso Brake, page 32
- Troubleshooting the Mobile Lift Cylinders and Casters, page 34

Troubleshooting the Carriage Assembly

Table 7 contains tips and troubleshooting information to assist you in diagnosing the most common carriage assembly problems. This table is not intended to cover every situation, but does include the most common problems that you may encounter.

Table 7 Carriage Assembly Troubleshooting

Problem	Possible Cause	Action
Simulator carriage is sluggish or halting in lift	The air supply is below 80 psi	Check the air supply.
	The carriage brake assembly has turned, causing damage to the air supply (clear)	If the carriage brake assembly has rotated, loosen the two button-head screws and rotate the carriage brake assembly so the air barb is unobstructed.
	Gas spring has lost its charge	Replace the gas spring.

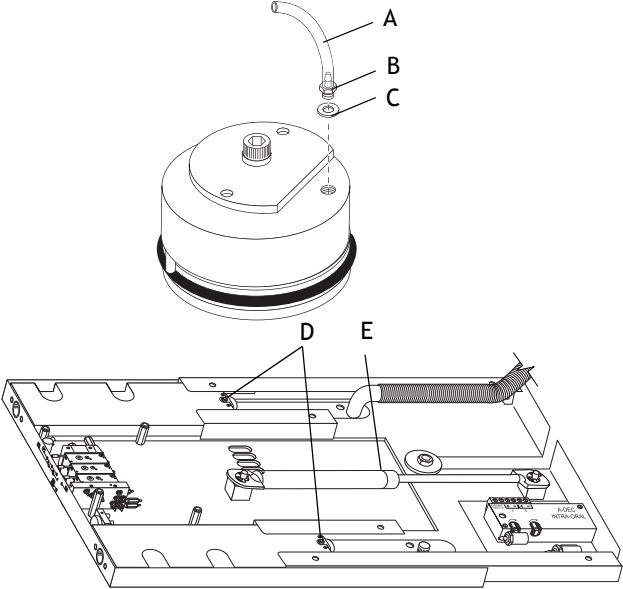
Problem	Possible Cause	Action
Air leaks from the barb	The air supply (clear) is damaged	Fix the , if it is kinked or cut.
	The barb is loose	Tighten the barb.
		
		(A) Air Supply ; (B) Barb; (C) Washer; (D) Carriage Brake Assembly; (E) Gas Spring
Air leaks from the brake cylinder	Nylon washer is damaged or worn	Replace the nylon washer.
	Brake disc O-ring is worn or damaged	Replace the brake disc O-ring.
	Brake disc is worn or damaged	Replace the brake disc.

Troubleshooting the Standard Simulator Control Block

Table 8 contains tips and troubleshooting information to assist you in diagnosing the most common problems associated with the Standard Simulator control block. This table is not intended to cover every situation, but does include the most common problems that you may encounter.

Table 8 Standard Simulator Control Block Troubleshooting

Problem	Possible Cause	Action
Air leaks at the syringe air, drive air flow control screws, or coolant air stem	O-ring is worn or damaged	Replace the O-ring.
	Stem is worn or damaged	Replace the stem.
Water leaks at the syringe water flow control screw or the coolant water system	O-ring is worn or damaged	Replace the O-ring.
	Stem is worn or damaged	Replace the stem.
Water leaks at the control block	Control block screws, barbs or washers are loose or damaged	Follow these steps: <ol style="list-style-type: none"> 1. Tighten the control block assembly screws. 2. Tighten all barbs and make sure the washers are not damaged. 3. Replace the diaphragm. 4. Replace the stem O-rings.

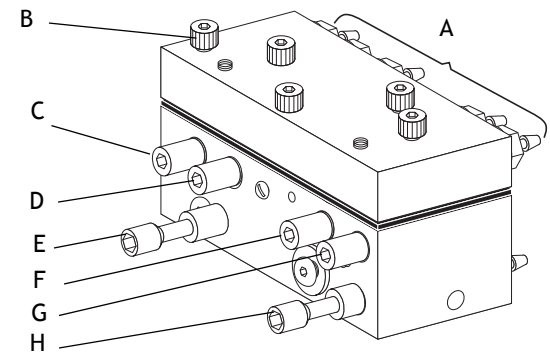

(A) Barbs; (B) Assembly Screw; (C) Handpiece #2, Drive Air; (D) Handpiece #1, Drive Air; (E) Air Coolant; (F) Syringe Air; (G) Syringe Water; (H) Water Coolant

Troubleshooting the Century Plus Control Block

Table 9 contains tips and troubleshooting information to assist you in diagnosing the most common carriage assembly problems. This table is not intended to cover every situation, but does include the most common problems that you may encounter.

Table 9 Century Plus Control Block Troubleshooting

Problem	Possible Cause	Action
Water leaks from the water vent hole (located between the control blocks)	Water valve cartridge has failed	<p>Replace the water valve cartridge if it is defective. After replacing the cartridge, test the unit. Make sure no water is leaking from the control block.</p> <ol style="list-style-type: none"> 1. Determine which control block water is leaking water. 2. Exchange the control block water valve cartridge with a known good one. 3. Retest the unit. Make sure no more water is leaking from any point of the control block. <p>If the water valve cartridge is not the problem, go to “Coolant water is leaking from one handpiece control block” on page 16.</p>

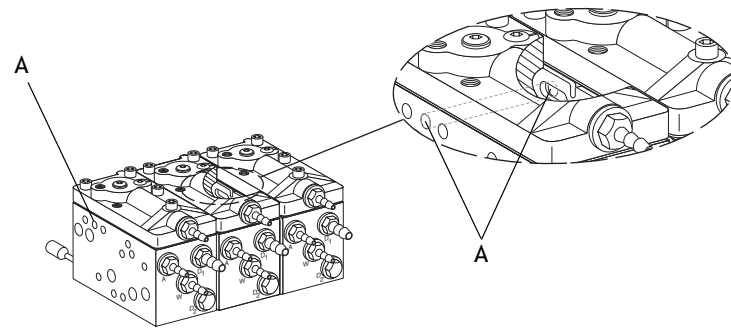

(A) Water Vent Hole (as shown in cutout, present on each side of each control block)

Problem	Possible Cause	Action
Coolant water is leaking from one handpiece control block	Valve stem or O-ring is worn or defective	If the water flow adjustment stem is leaking, follow these steps: <ol style="list-style-type: none"> 1. Remove the valve stem from the block. 2. Inspect the O-ring and the valve stem. 3. Replace all defective parts and test the unit.
	Water valve cartridge is loose or defective	If the water valve cartridge is leaking, follow these steps: <ol style="list-style-type: none"> 1. Tighten the cartridge and test the unit. 2. Exchange the cartridge with a known good one and test the unit. 3. Replace the cartridge, if it is defective.
	Check valve (flush) cartridge is loose or defective	If the check valve (flush) cartridge is leaking, follow these steps: <ol style="list-style-type: none"> 1. Tighten the cartridge and test the unit. 2. Exchange the cartridge with a known good one and test the unit. 3. Replace the cartridge, if it is defective.
	Control block tie bolts are loose or the side gasket may have failed	If the control block bolts are loose, follow these steps: <ol style="list-style-type: none"> 1. Tighten the tie bolts and test the unit. 2. If these bolts are not loose, the side gasket may have failed. 3. Replace the gasket and retest the unit.

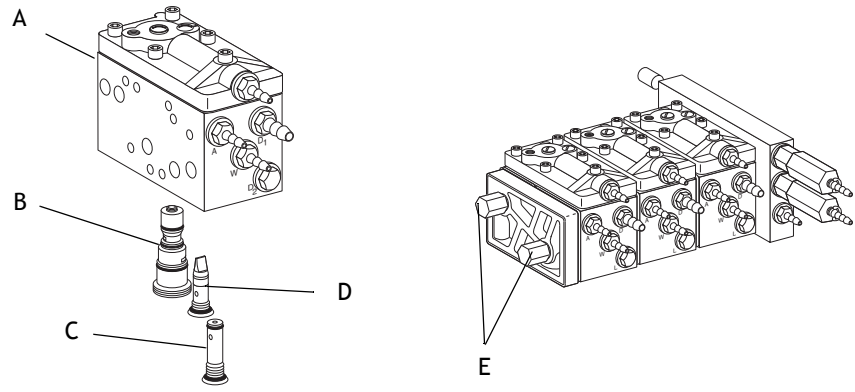

(A) Water Flow Adjustment Stem (on back side); (B) Water Valve Cartridge; (C) Air Bleed Cartridge; (D) Check Valve (Flush) Cartridge; (E) Tie Bolts

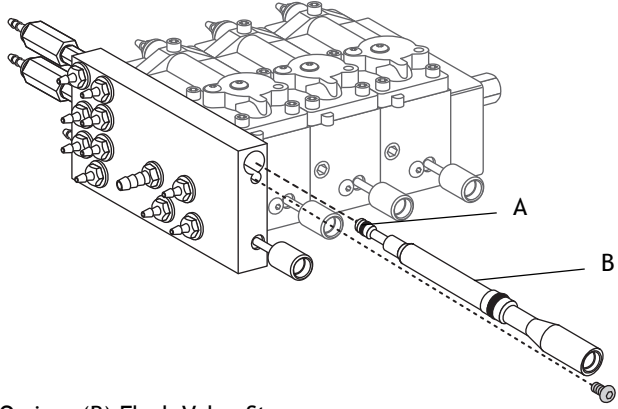
Problem	Possible Cause	Action
Coolant water leaks from all handpieces	Handpiece flush valve system has failed	Follow these steps: <ol style="list-style-type: none"> 1. Remove the flush valve stem from the control block manifold and inspect the small O-ring and the valve stem. 2. Replace all defective parts and test the unit. <div style="text-align: center;">  <p>(A) Small O-ring; (B) Flush Valve Stem</p> </div>
Coolant water leaks from one handpiece whether in or out of its holder	Water valve cartridge has failed	Follow these steps: <ol style="list-style-type: none"> 1. Exchange the cartridge with a known good one and test the unit. 2. Replace the cartridge if it is defective. 3. Test the unit, and make sure no water is leaking from the control block.
Coolant water leaks from all wet handpieces when the dry handpiece is used	Dry block is defective	If the wet handpieces leak when the coolant water flow control stem is turned completely in to accommodate a dry handpiece, install a Dry Block Conversion Kit (part number 38.0648.00) in the dry handpiece control block.

Problem	Possible Cause	Action
No coolant water from any of the handpieces	Wet/Dry Toggle is off	Turn the Wet/Dry toggle on the foot control to the On position and test the unit.
	Water is not reaching the control block manifold	<p>Press the flush valve stem to see if water is reaching the control block manifold.</p> <p>If no water flows and the unit is not equipped with a Self-contained Water System, check the water filter regulator for proper operation.</p> <p>If the unit is equipped with a Self-contained Water System, follow these steps:</p> <ol style="list-style-type: none"> 1. Make sure the bottle is filled with water. 2. Verify that the bottle is pressurized by carefully loosening the bottle. A continuous flow of air from the bottle should be heard. If the flow of air stops, air flow to the bottle is restricted. 3. Check the inlet barb on the cap and the to assure they are not plugged. 4. Check the 40 psi pre-regulator on the air filter/regulator assembly for proper operation.
	Control block manifold signal air passage is plugged, to the foot control is crimped, or the foot control relay has failed	<p>Follow these steps:</p> <ol style="list-style-type: none"> 1. Check to make sure that the coolant water signal is coming from the foot control to the control block manifold. 2. Remove the short dashed green line from the control block manifold and depress the foot control. 3. The control block manifold signal air passage may be plugged. Unplug or replace the manifold. 4. Trace the back to the foot control and check for crimped or failed foot control relay.
Coolant water leaks from all wet handpieces except the one being used	The Check Valve (Flush) cartridge failed on the handpiece being used	Remove and replace the Check Valve (Flush) cartridge for the handpiece with a known, good cartridge.

Problem	Possible Cause	Action
No coolant water from one handpiece	Coolant water flow control is not properly adjusted	Refer to “Making Handpiece Adjustments” on page 53 and page 54, and adjust the coolant water flow.
	Water valve cartridge has failed	Exchange the cartridge with a known good one and test the unit.
<p>(A) Vent Screw; (B) Control Block Top Cap Diaphragm; (C) Coolant Water Outlet; (D) Check Valve (Flush) Cartridge; (E) Air Bleed Cartridge; (F) Water Valve Cartridge</p>		
Vent screw on top of the control block is loose or missing	Vent screw on top of the control block is loose or missing	Tighten or replace the screw and then test the unit.
	Water passage in the block is plugged	<p>Follow these steps:</p> <ol style="list-style-type: none"> 1. Turn the unit off, and then remove the water valve cartridge. 2. Momentarily turn the unit on. If the water flows out the bottom of the block from the cartridge position, then the passage between there and the water outlet is plugged.

Problem	Possible Cause	Action
No drive air at one handpiece	Handpiece selector valve is not in the correct position	Adjust the selector valve to the correct position and retest the unit.
	Drive air flow control for the handpiece is not properly adjusted	Refer to “Making Handpiece Adjustments” on page 53 and page 54, and adjust the drive air flow for that handpiece.
		<div data-bbox="1155 535 1659 828" data-label="Image"> </div> <p data-bbox="1050 836 1407 868">(A) Drive Air Flow Control Stem</p>
	Holdback signal is pinched or kinked	<p data-bbox="1050 876 1260 909">Follow these steps:</p> <ol data-bbox="1050 909 1890 1006" style="list-style-type: none"> <li data-bbox="1050 909 1890 941">1. Inspect the between the handpiece selector valve and the control block. <li data-bbox="1050 941 1890 974">2. Inspect the handpiece selector valve for proper operation. <li data-bbox="1050 974 1890 1006">3. Remove any kinks or sharp bends in the and retest the unit.

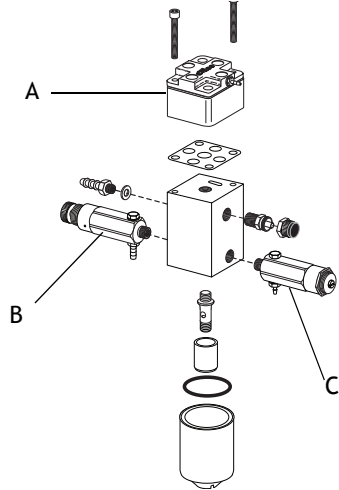
Problem	Possible Cause	Action
Inadequate drive air to all handpieces	Air supply to the unit is inadequate	Verify that the instrument air supplied to the unit is the minimum required by the handpiece manufacturer, and adjust it, if necessary. The typical requirement for a single high-speed handpiece is 1.5 CFM at 35 psi. The typical requirement for a single low-speed handpiece is 3.0 CFM at 40 psi.
	Drive air supply is kinked	Trace the black dashed orange from the control block manifold back through the unit to the foot control. Straighten any kinks in the and retest the unit.
	Foot control has failed	Check the foot control for proper operation. Check to make sure the outlet barb is unobstructed. If it is obstructed, remove the obstruction, lube the assembly, and retest the unit.
	Air regulator or pre-regulator failed, or required adjustment	Test the air regulator and pre-regulator for proper operation. Replace components, as necessary.
		
		(A) Regulator Assembly; (B) 80 psi Pre-regulator; (C) 40 psi Pre-regulator
Air filter in the utility module is partially plugged		Replace the air filter, as necessary, and retest the unit. Assemble the filter with the bevelled (stepped) edge toward the manifold.

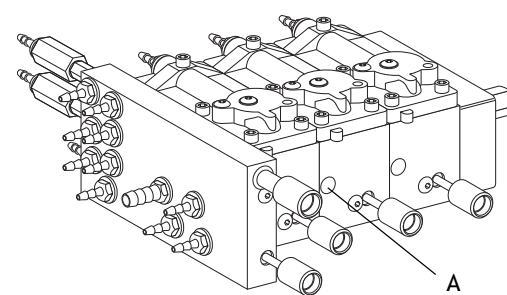
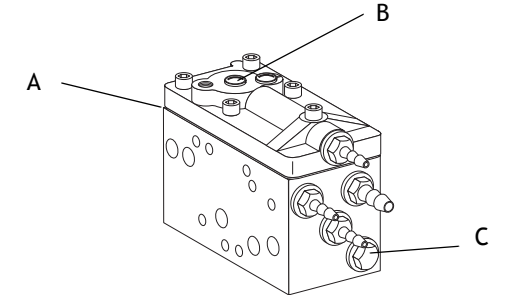
Problem	Possible Cause	Action
Inadequate drive air at one handpiece	Drive air flow control for the handpiece is not properly adjusted	Refer to “Making Handpiece Adjustments” on page 53 and page 54, and adjust the drive air flow for that handpiece.
		
Auxiliary drive port (D2) on the control block is leaking		Tighten the fitting. Replace the washer, if necessary.
		
Control block top cap or diaphragm is leaking		Tighten the top cap screws. If leaking continues, remove the top cap from the control block and inspect the diaphragm for perforations. Replace the diaphragm, if necessary.
Drive air flow control stem is damaged		Remove the drive air flow control stem from the control block. Inspect the O-ring and the stem. Replace any damaged items.
Handpiece exhaust is restricted		Inspect the exhaust and remove any restrictions.

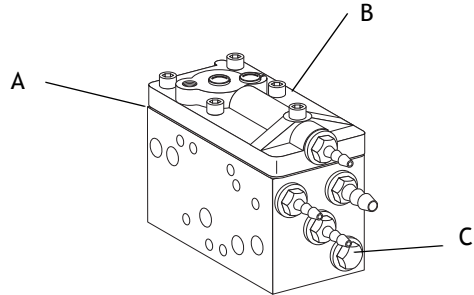
Problem	Possible Cause	Action
No coolant air at one handpiece	Handpiece may be plugged or the handpiece may be kinked, pinched, or damaged	Inspect the handpiece to assure that it is not plugged. Inspect the handpiece and be sure that it is not plugged, kinked, or damaged. Replace any damaged handpiece .
Inadequate coolant air at all handpieces	Coolant air is not properly adjusted	Refer to “Making Handpiece Adjustments” on page 53 and page 54, and adjust the coolant water flow.
	Coolant air stem is damaged	Remove the stem and inspect the stem and the O-ring for damage. Replace all defective parts and test the unit.
	Foot control is kinked, pinched, or damaged	Relieve any kinks or pinched areas. If the is damaged, it must be replaced.
	Foot control valve or relay valve in the foot control has failed	Test and replace components, as needed.
Inadequate coolant air at one handpiece	Handpiece is partially plugged	Insert a small wire through the air passage in the handpiece terminal to dislodge debris.
	Control block top cap diaphragm has perforated and is leaking	Replace the diaphragm, if necessary.
		 <p>(A) Control Block Top Cap Diaphragm; (B) Control Block Top Cap; (C) Auxiliary Drive Port (D2)</p>
All handpieces run while in their holders when the foot control is pressed	Unregulated holdback signal air is not present at the control block	Check the handpiece selector valve for proper operation.

Troubleshooting the Foot Control

Table 10 contains tips and troubleshooting information to assist you in diagnosing the most common foot control problems. This table is not intended to cover every situation, but does include the most common problems that you may encounter.

Table 10 Foot Control Troubleshooting

Problem	Possible Cause	Action
Audible leakage when foot control is not being used	Mounting screws are loose	Check to make sure that the mounting screws in the bottom of the base plate to make sure they are tight. If leakage has stopped, then test the unit.
	Internal connections are loose	Remove the cover and check the internal s for secure connections.
	Leakage is coming from the exhaust holes on the signal relay valve	Check for leakage from the exhaust holes on the signal relay valve. If there is leakage, do the following: <ol style="list-style-type: none"> 1. Move the master On/Off toggle to the Off position and bleed the system of air pressure. 2. Inspect the stem and O-rings for debris or defects. 3. Inspect the seat for debris and defects.
	Parts are defective	Replace any defective parts. Lubricate the O-rings, reassemble and test the foot control.
Leakage is coming from the diaphragm	Check for leakage round the diaphragm. If there is leakage, tighten the two screws securing the signal relay valve to the foot control valve. If there is still leakage, replace the diaphragm.	

Problem	Possible Cause	Action
Audible leakage when foot control is in use	Diaphragm has failed	Check for a failed diaphragm. Tighten the two screws securing the signal relay valve to the foot control valve. If there is still leakage, replace the diaphragm.
	Leakage is coming from the exhaust holes on the signal relay valve	Check for leakage from the exhaust holes on the signal relay valve. If there is leakage, do the following: <ol style="list-style-type: none"> 1. Move the master On/Off toggle to the Off position and bleed the system of air pressure. 2. Inspect the stem and O-rings for debris or defects. 3. Inspect the seat for debris and defects.
	Leakage is coming from the exhaust holes on the signal relay valve	Check for leakage from the exhaust holes on the signal relay valve. If there is leakage, do the following: <ol style="list-style-type: none"> 1. Move the master On/Off toggle to the Off position and bleed the system of air pressure. 2. Inspect the stem and O-rings for debris or defects. 3. Inspect the seat for debris and defects.
	Parts are defective	Replace any defective parts. Lubricate the O-rings, reassemble and test the foot control.
	Outlet barb or connections on the signal relay valve are loose	Check the outlet barb and on the signal relay valve. Tighten the barb, or replace the .
Inadequate air flow	Air pressure is low due to obstructions or pinched or parts are defective in the valve assembly	Follow these steps: <ol style="list-style-type: none"> 1. Check the air pressure. If the air pressure drops by more than 15 psi when the syringe air button and foot control are depressed: <ul style="list-style-type: none"> • Check for pinched foot control . • Check for a plugged filter in the air filter/regulator (floor box). • Check for an obstructed outlet barb on the signal relay valve. 2. Move the master On/Off toggle to the Off position and bleed the system of air pressure. 3. Remove debris and replace any defective parts in the valve assembly. Lubricate the O-rings, reassemble, and test the foot control.

Problem	Possible Cause	Action
Coolant water continues after releasing the foot control	Signal relay valve is sticky or is kinked or plugged	<p>Check these in the following order:</p> <ol style="list-style-type: none"> 1. Check for a sticky signal relay valve. 2. Move the master On/Off toggle to the Off position and bleed the system of air pressure. 3. Remove the signal relay valve, clean it, lube the parts, and reassemble it. 4. Test the foot control. 5. Check for kinked or plugged somewhere between the foot control relay and the control head.
Sluggish Foot Control	Signal relay valve stem is sticky	<p>Follow these steps:</p> <ol style="list-style-type: none"> 1. Check the valve stem to see if it is sticking. 2. Move the master On/Off toggle to the Off position and bleed the system of air pressure. 3. Remove the signal relay valve, clean it, lube the parts, and reassemble it. 4. Test the foot control.

Troubleshooting the Autoclavable Syringe

Table 11 contains tips and troubleshooting information to assist you in diagnosing the most common autoclavable syringe problems. This table is not intended to cover every situation, but does include the most common problems that you may encounter.

Table 11 Autoclavable Syringe Troubleshooting

Problem	Possible Cause	Action
Air or water is leaking from one of the valve assemblies	Valve assembly is worn or damaged	Replace the valve assembly.
Air or water is leaking from the syringe tip retainer	Nut assembly is loose or damaged	Check the following: <ul style="list-style-type: none"> • Make sure the syringe nut assembly is properly installed and tightened (use a 5/32" hex key). • Replace the syringe nut assembly, if necessary.
	O-rings are worn or damaged	Replace the O-rings.
No air and/or water is issuing from the syringe	Air or water is off or blocked	Follow these steps: <ol style="list-style-type: none"> 1. Make sure the master On/Off toggle is in the On position. 2. Make sure the air and water supplies are turned on. 3. Check the for kinks or breaks.

Troubleshooting the HVE Valve, Central Vacuum

Table 12 contains tips and troubleshooting information to assist you in diagnosing the most common HVE problems. This table is not intended to cover every situation, but does include the most common problems that you may encounter.

Table 12 HVE Troubleshooting

Problem	Possible Cause	Action
Water or vacuum is leaking at the HVE	Rotary assembly is not installed properly	Make sure that the rotary assembly is fully inserted into the O-ring groove side of the HVE valve body.
	O-rings are worn or damaged	Replace the O-rings.

Troubleshooting the Air Vacuum System (AVS)

Table 13 contains tips and troubleshooting information to assist you in diagnosing the most common problems with the air vacuum system. This table is not intended to cover every situation, but does include the most common problems that you may encounter.

Table 13 Air Vacuum System (AVS) Troubleshooting

Problem	Possible Cause	Action
Air leaks at the cap on vacuum generator	Diaphragm is worn or damaged	Replace the diaphragm.
	Vacuum jet O-ring is worn or damaged	Replace the vacuum jet O-ring.
	Screws are loose	Tighten the screws.
Air leaks at the vacuum body	Air bleed cartridge is worn or damaged	Replace the air bleed cartridge.
No vacuum is present, but generator is operating	Vacuum jet is dirty or damaged	Follow these steps: <ol style="list-style-type: none"> 1. Clean the vacuum jet. (To access the vacuum generator and muffler tray, remove the screw and slide the tray assembly out from under the Simulator.) 2. If cleaning doesn't fix the problem, replace the vacuum jet.

Problem	Possible Cause	Action
Air is leaking at the vacuum jet	Vacuum jet O-ring is worn or damaged	Replace the vacuum jet O-ring.
	Vacuum jet is damaged	Replace the vacuum jet.
Vacuum generator is noisy	Muffler is dirty or damaged	Follow these steps: <ol style="list-style-type: none"> 1. Clean the muffler. (To access the vacuum generator and muffler tray, remove the screw and slide the tray assembly out from under the Simulator.) 2. If cleaning doesn't fix the problem, replace the muffler.
	Muffler is not properly installed	Loosen the cover screw and push muffler towards the generator. Tighten the screw again.

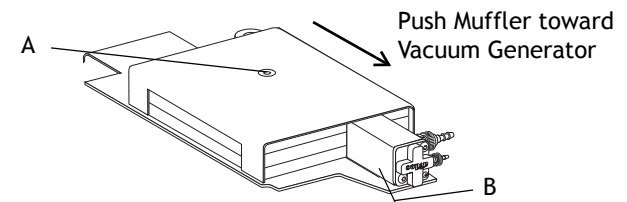

(A) Screw; (B) Vacuum Generator

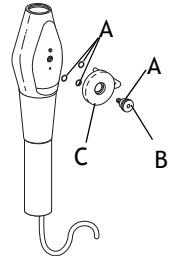
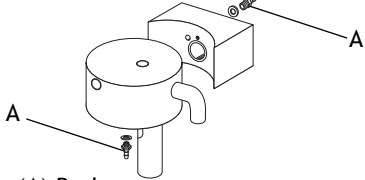
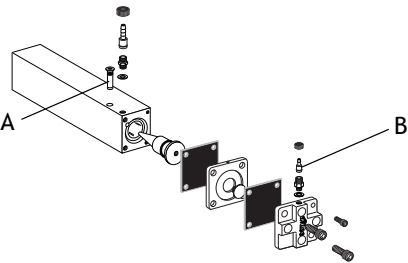
Problem	Possible Cause	Action
Vacuum generator does not turn off	Holdback air is leaking	<p>Follow these steps:</p> <ol style="list-style-type: none"> 1. Check the AVS handpiece rotor for the O-rings. Replace or lube with silicone, as necessary.  <p>(A) O-ring; (B) Retainer; (C) Rotor</p> <ol style="list-style-type: none"> 2. Trace the 1/8" holdback tube for leaks at the barbs. Two of the barbs are located on the canister lid and one is on the generator (see figure below).  <p>(A) Barb</p>
	Holdback air is plugged	<p>Replace the air bleed cartridge in the generator. If the problem returns within three months, it may be necessary to use a larger orifice cartridge (see page 72).</p>  <p>(A) Air Bleed Cartridge; (B) Barb</p>

Troubleshooting the Torso Brake

Table 14 contains tips and troubleshooting information to assist you in diagnosing the most common problems with torso brake. This table is not intended to cover every situation, but does include the most common problems that you may encounter.

Table 14 Torso Brake Troubleshooting

Problem	Possible Cause	Action
Torso assembly does not move or is difficult to position	Air pressure is off or blocked	<p>Follow these steps:</p> <ol style="list-style-type: none"> 1. Make sure the air compressor is turned on and the pressure is at least 60 psi (80 psi is preferable). If air pressure is acceptable, go to step 2. 2. Make sure the air pressure at the brake is at least 60 psi (80 psi is preferable). Remove the  from the brake disc restrictor barb and check the air pressure using a gauge. If the pressure is low, locate the pinched and repair. 3. Check to make sure the restrictor barb is not plugged. If the barb is plugged, replace the restrictor barb. 4. If necessary, adjust the brake; see “Adjusting the Torso Brake (Rotation)” on page 57.

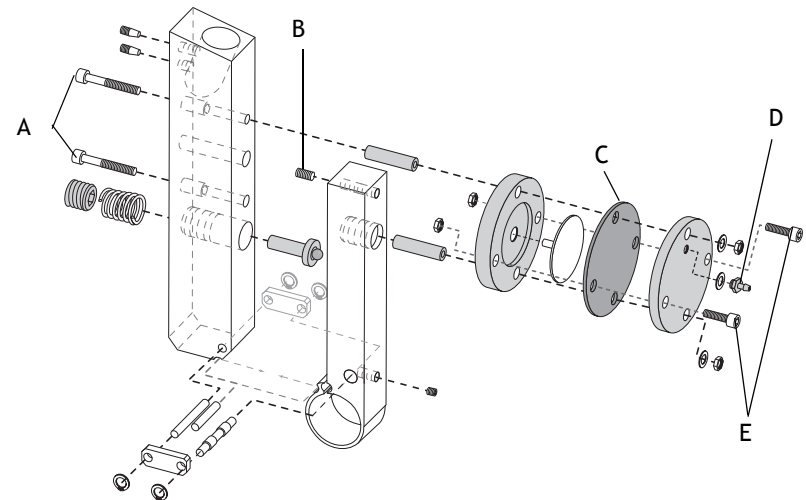

(A) Brake Cylinder Cover Screws; (B) Torso Brake Setscrew; (C) Diaphragm; (D) Restrictor Barb; (E) Brake Cover Cylinder Screws

Problem	Possible Cause	Action
The torso drops	Torso brake adjustment setscrew is not installed	Check to make sure the torso brake setscrew is installed. If not, install the setscrew and follow the brake adjustment instructions on page 57.
	Torso brake adjustment setscrew is not adjusted properly	If the setscrew is installed, check to make sure it is adjusted properly. Rotate to the left to increase tension. Turn the setscrew in small increments; a small turn makes a large change. If this does not work, follow the torso brake adjustment instructions on page 57.
The torso assembly is adjustable, but it tends to drop.	Air pressure is not adjusted properly or blocked or the diaphragm is damaged	<p>Follow these steps:</p> <ol style="list-style-type: none"> 1. Make sure the air compressor is turned on and the pressure is at least 60 psi (80 psi is preferable). If air pressure is acceptable, go to step 2. 2. Make sure the air pressure at the brake is at least 60 psi (80 psi is preferable). Remove the from the brake disc restrictor barb and check the air pressure using a gauge. If the pressure is low, locate the pinched and repair. 3. Check to make sure the restrictor barb is not plugged. If the barb is plugged, replace the restrictor barb. 4. Press the torso adjustment button and listen for an air leak. If you can hear an air leak, the diaphragm is damaged. Replace the diaphragm. 5. If necessary, adjust the brake; see instructions on page 57.
Air is leaking from the torso assembly	is damaged or loose at the restrictor barb	Repair the and/or tighten the restrictor barb.
	Brake cylinder cover is loose	Tighten the brake cylinder cover screws.
	Diaphragm is damaged or is incorrectly plumbed at the torso buttons	If air is leaking from the brake cylinder plunger opening, replace the diaphragm. If not, look for incorrectly plumbed at the torso buttons.

Troubleshooting the Mobile Lift Cylinders and Casters

Table 15 contains tips and troubleshooting information to assist you in diagnosing the most common problems with the mobile lift and cylinder casters. This table is not intended to cover every situation, but does include the most common problems that you may encounter.

Table 15 Mobile Lift Cylinders and Casters Troubleshooting

Problem	Possible Cause	Action
Unit is difficult to move	Castors are worn or damaged	Replace one or more casters.
Air is leaking at from the barb	Barb is loose	Tighten the barb.
	Air (black) is damaged	Check the air (black) to the barb is not damaged. If it is, fix or replace it.
	Nylon washer is worn or damaged	Replace the nylon washer.
Air is leaking at the lift cylinder	Lift seal is worn or damaged	Replace the lift seal.

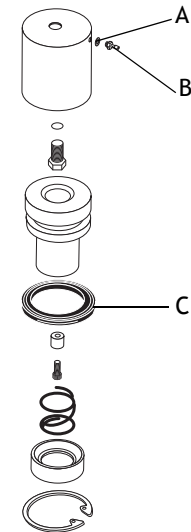

(A) Nylon Washers; (B) Barb; (C) Lift Seal

DENTAL LIGHTS

This section contains information on the dental lights options for the simulators. It provides adjustment and maintenance information, illustrated parts breakdowns, as well as troubleshooting information.

DENTAL LIGHT CONTENTS

- **Adjustments and Maintenance**
 - 6300 Dental Light Adjustments, page 37
 - 6300 Light Head Rotation, page 37
 - Performer Dental Light Adjustments, page 39
 - Flexarm Adjustments for 6300 and Performer Lights, page 41
 - Maintaining the 6300 and Performer Dental Light, page 42
 - 6300 Dental Light Lamp Replacement, page 43
 - Performer Dental Light Lamp Replacement, page 44
- **Illustrated Parts Breakdown**
 - 6300 Light Head, page 46
 - Performer Light Head, page 47
- **Troubleshooting the Dental Light, page 48**

Figure 7 6300 and Performer Dental Lights

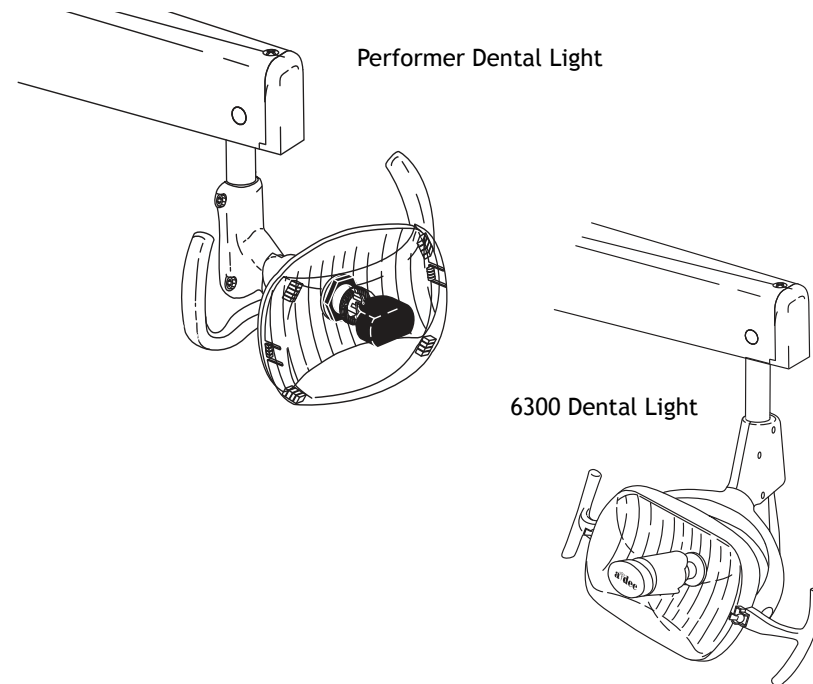

Adjustments and Maintenance

This section contains adjustment and maintenance information for the dental lights options.

ADJUSTMENTS AND MAINTENANCE CONTENTS

- 6300 Dental Light Adjustments, page 37
- 6300 Light Head Rotation, page 37
- Performer Dental Light Adjustments, page 39
- Flexarm Adjustments for 6300 and Performer Lights, page 41
- Maintaining the 6300 and Performer Dental Light, page 42
- 6300 Dental Light Lamp Replacement, page 43
- Performer Dental Light Lamp Replacement, page 44

6300 Dental Light Adjustments

The light is preset for proper illumination at 27.6 inches (700 mm) from the black nose piece to the oral cavity. The light has a focal adjustment range between 18" and 31" (460 mm and 790 mm).

■ Focus

1. Place a white towel over the chair headrest to represent the oral cavity.
2. Position the light head at the distance normally used when working in the oral cavity (select a distance representative of most procedures).
3. Turn the light ON.
4. Use a large screwdriver to turn the focus adjusting screw until the light, within the borders of the light pattern, is most uniform.

6300 Light Head Rotation

The light head needs adjusting if it is difficult to position, moves too easily, or tends to slip out of position. To adjust:

■ Left/Right Rotation (Horizontal)

Turn the adjustment screws beginning with the screw at the top of the switch housing:

- If the light head moves too easily, or tends to drift out of position, increase the tension by turning the screws right.
- If the light is difficult to move, loosen the tension by turning the screws left.

Figure 8 Rotation Adjustment

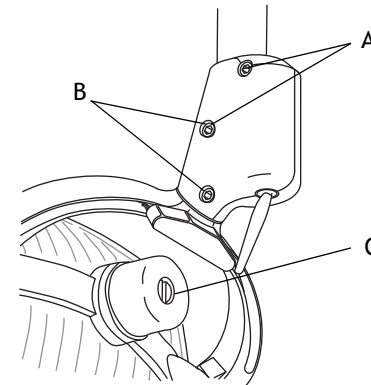

(A) Left/Right Rotation Tension Screw; (B) Diagonal Rotation Tension Screw; (C) Focus Adjusting Screw

Figure 9 Left/Right Rotation

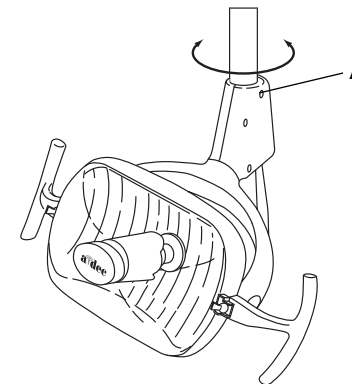

(A) Top Adjustment Screw

■ **Diagonal Rotation (Third Axis)**

1. Turn the adjustment screws, beginning with the screw at the bottom of the switch housing:
 - If the light head moves too easily, or tends to drift out of position, increase the tension by turning the screws right.
 - If the light head is difficult to move, loosen the tension by turning the screw left.
2. Tighten the adjustment screw until they are tight to eliminate all movement in the diagonal axis.

■ **Up/Down Rotation (Vertical)**

This adjustment only needs to be made to one side of the light head. To adjust:

1. Loosen the setscrew.
2. Remove the light yoke plug.
3. Use a large flat-blade screwdriver to turn the adjustment screw under the light yoke plug.
 - If the light head moves too easily, or tends to drift out of position, increase the tension by turning the screw right.
 - If the light head is difficult to move, loosen the tension by turning the screw left.
4. Retighten the setscrew, and reinstall the light yoke plug.

Figure 10 Diagonal Axis Rotation

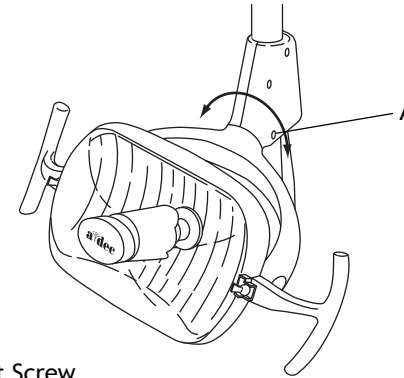

(A) Bottom Adjustment Screw

Figure 11 Up/Down Rotation

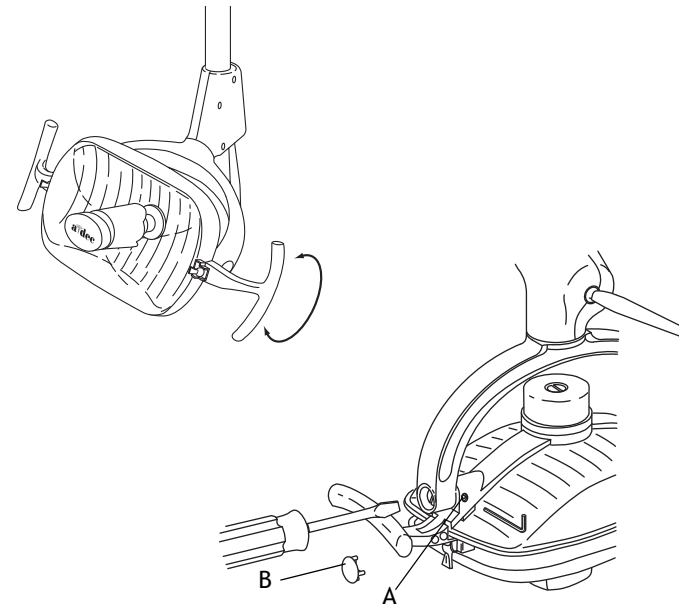

(A) Setscrew; (B) Light Yoke Plug

Performer Dental Light Adjustments

■ Focus the Light

1. Loosen the focus adjustment screw. Move the bulb socket in or out of the reflector housing until the light is focused.



WARNING To avoid personal injury, be sure that the light has cooled before touching it.

2. Tighten the focus adjustment to fully secure the bulb socket.

■ Adjust the Light Head Vertical Tension

1. Turn Off the dental light.
2. Turn the vertical tension adjustment screw right to increase tension. Turn the adjustment screw left to decrease tension.

Figure 12 Adjust the Light Head Vertical Tension

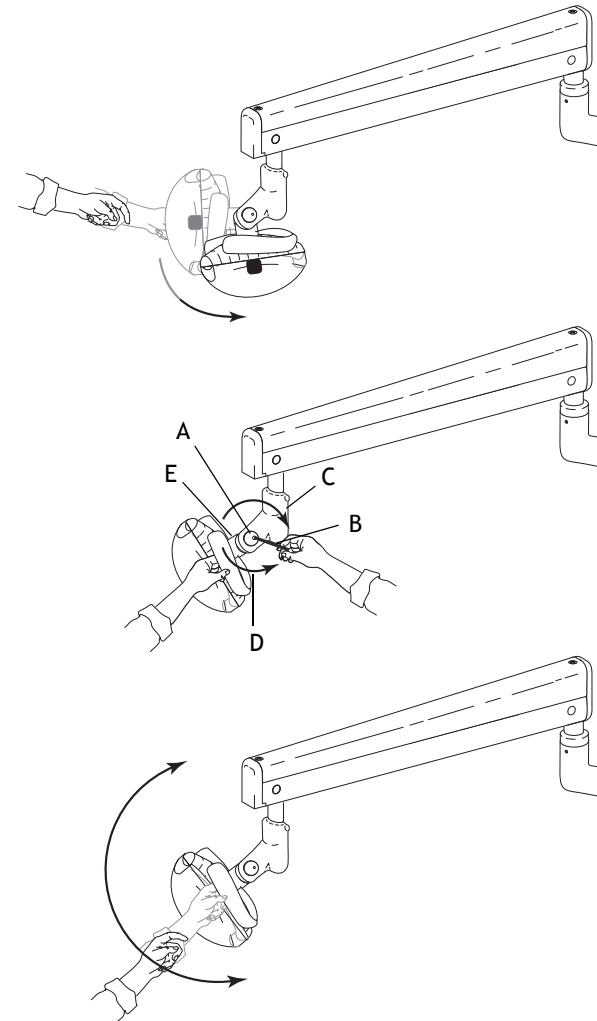

(A) Vertical Tension Adjustment Screw; (B) 5/16" Hex Key; (C) Increase Tension; (D) Decrease Tension; (E) Focus Adjustment Screw

■ **Adjust the Light Head Horizontal Tension**

1. Turn Off the dental light.
2. Turn the horizontal tension adjustment screw right to increase tension. Turn it left to decrease tension.

Figure 13 Adjust the Light Head Horizontal Tension

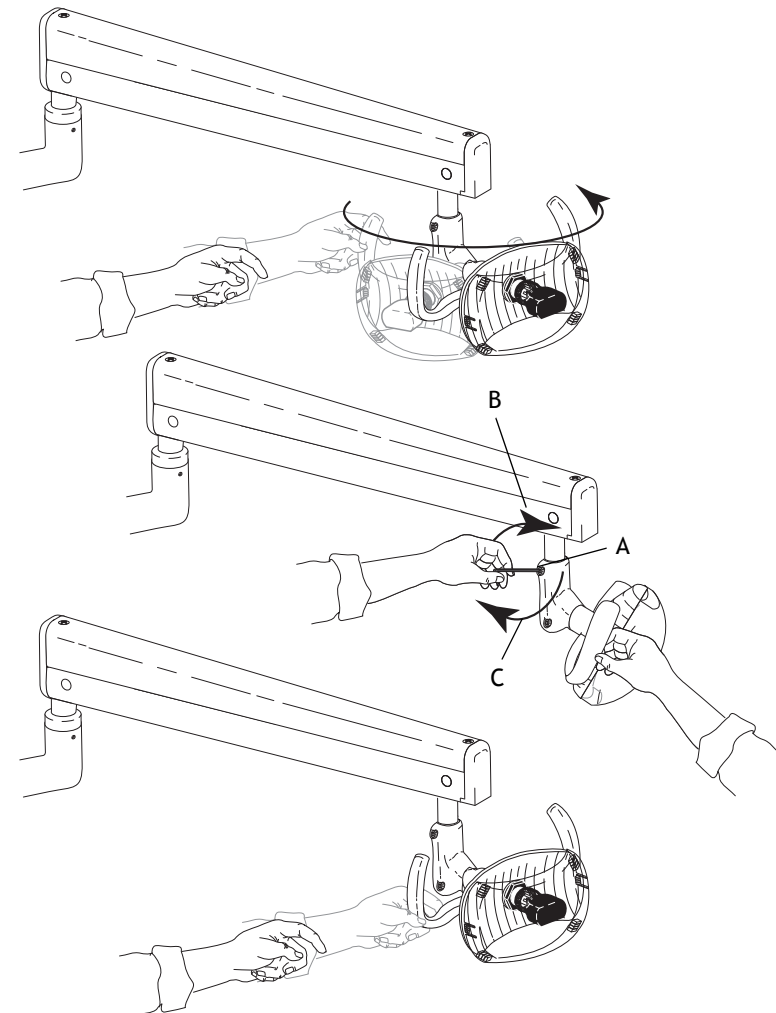

(A) Horizontal Tension Adjustment Screw (Use a 5/16" Hex Key); (B) Increase Tension; (C) Decrease Tension

Flexarm Adjustments for 6300 and Performer Lights

To adjust:

1. Remove the screw and cover from the flexarm.
2. Turn the tension adjustment nut inside the flexarm using a 1/2" open end wrench.

3. Tighten the nut by turning it right, if the flexarm moves too easily, or tends to drift down by itself.
4. Loosen the nut by turning it left, if the arm drifts up.



NOTE You must install a travel stop limit kit (P/N 90.1044.00) to limit the upward or downward motion of the flexarm.

Figure 14 Flexarm Adjustments

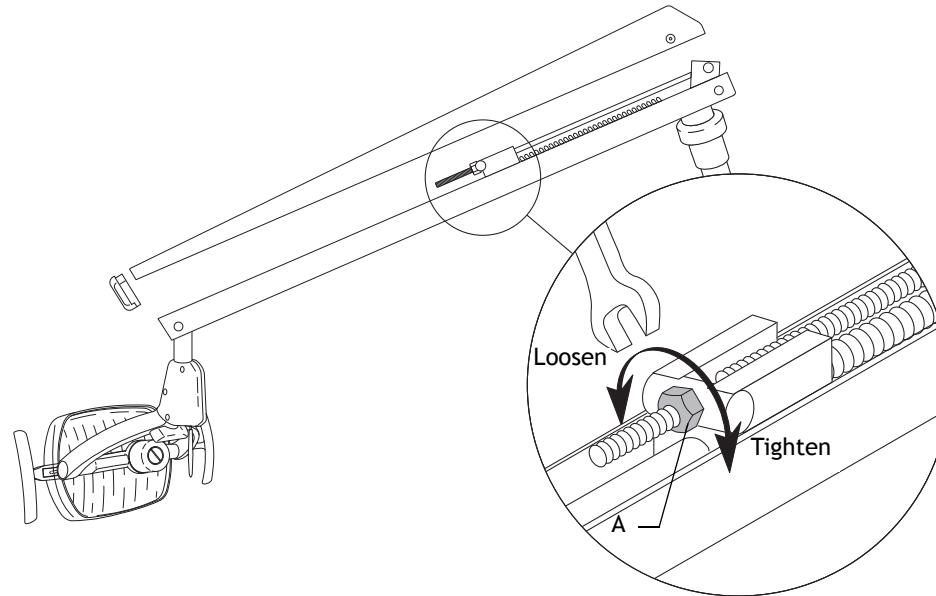

(A) Adjustment Nut

Maintaining the 6300 and Performer Dental Light

■ Light Shield Cleaning

1. Turn Off the dental light.



WARNING To avoid personal injury, be sure that the light has cooled before cleaning it.

2. Remove the light shield.
3. Use a 100% cotton gauze pad or a soft, dry, lint-free cloth to clean the light shield and reflector.

If necessary, soak the pad or cloth with water or with a diluted solution of mild dish washing liquid before cleaning. Make certain no residue remains on the surface.

Do not use abrasives or chlorine (such as household bleach) on the surface of the reflector. These can damage or discolor the reflector surface, impairing the effectiveness.



CAUTION Do not rub heavily, clean the light shield when it is hot, or soak the shield assembly in cleaning solution. Doing so may damage the shield assembly components. Clean the light shield only as instructed.

Figure 15 Light Shield Cleaning - 6300 Dental Light

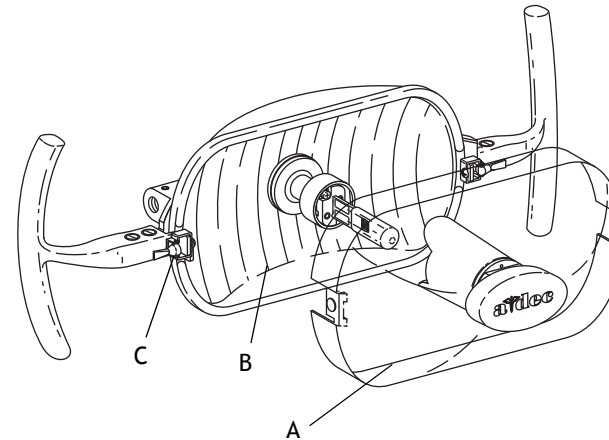

(A) Light shield; (B) Reflector; (C) Toggle

Figure 16 Light Shield Cleaning - Performer Dental Light

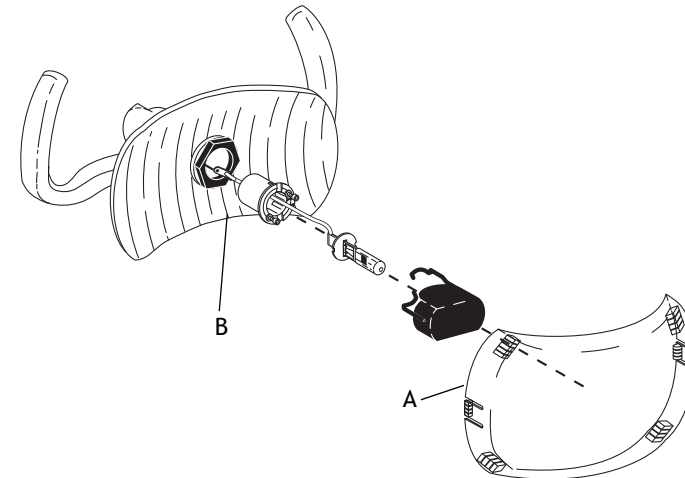

(A) Light shield; (B) Reflector

6300 Dental Light Lamp Replacement

Pull the spare lamp holder from the light head. Remove the lamp from the holder, but do not remove the outer wrapper. Finger oils can affect light performance and severely limit lamp life. If lamp is inadvertently touched, gently clean it with cotton dampened with isopropyl or ethyl alcohol.



WARNING To avoid burning fingers, allow the lamp to cool before removing. Never operate the light with the light shield removed. The clear shield minimizes UV light output. The light shield is also protection in the unlikely event that the lamp shatters.

1. Turn Off the light, and allow the light to cool.
2. Release the toggles on the light shield and set the shield aside.
3. Use a gauze pad or cloth to protect fingers. Carefully pull the old lamp from its socket and discard.
4. Hold the new lamp in its outer wrapper with the pins facing away, and carefully insert it in the socket. The lamp base is fragile and can break under excess pressure.
5. Remove and discard the outer wrapper, reinstall the light shield, and secure with the toggles.
6. Verify the operation of the light by turning it on and operating it at each intensity setting.



CAUTION Use of halogen bulbs other than A-dec P/N 041.179.01 (OSRAM HLX 64640, 150W 24V) may result in damage to the bulb socket.

Figure 17 Remove Lamp from Holder

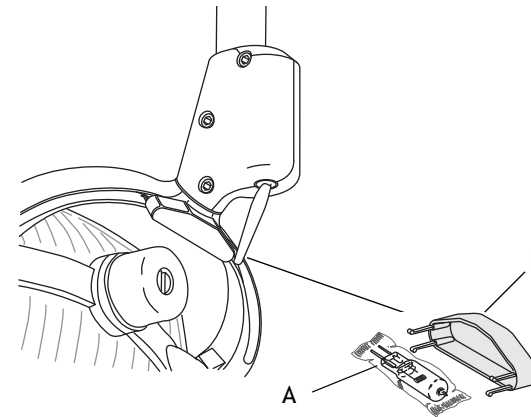

(A) Lamp; (B) Holder

Figure 18 Insert Lamp

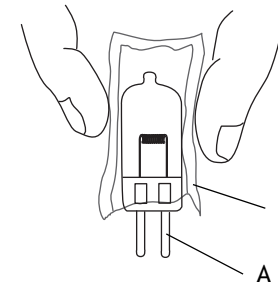

(A) New Lamp; (B) Outer Wrapper

Performer Dental Light Lamp Replacement

Do not remove the outer wrapper from the new lamp. Finger oils can affect light performance and severely limit lamp life. If lamp is inadvertently touched, gently clean it with cotton dampened with isopropyl or ethyl alcohol.



WARNING To avoid burning fingers, allow the lamp to cool before removing. Never operate the light with the light shield removed. The clear shield minimizes UV light output. The light shield is also protection in the unlikely event that the lamp shatters.

1. Turn Off the light, and allow the light to cool.
2. Remove the light shield and the bulb cap.
3. Loosen the screws to remove the lamp. Use a gauze pad or cloth to protect your fingers.
4. Disconnect the power wire.
5. Install the new lamp using the outer wrapper, by connecting the power wire and positioning the lamp. Retighten the screws.
6. Discard the outer wrapper. Replace the bulb cap and light shield.
7. Verify the operation of the light by turning it on.

Figure 19 Replacing the Performer Dental Lamp

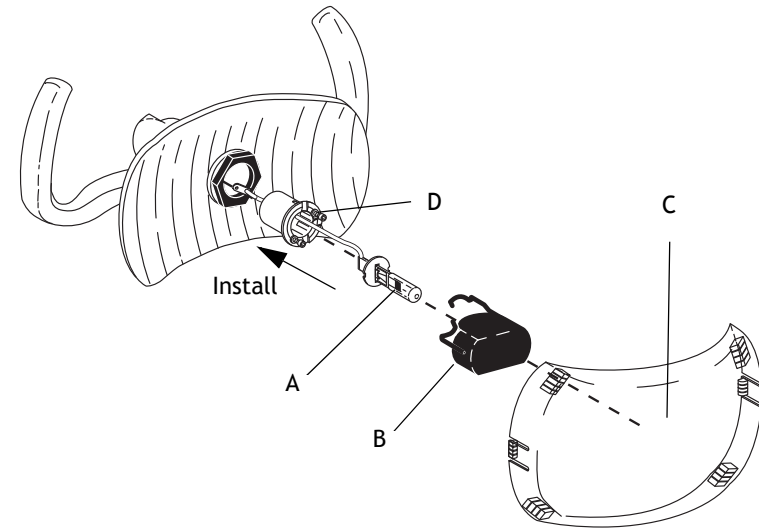

(A) Lamp; (B) Bulb Cap; (C) Light Shield; (D) Screws

Illustrated Parts Breakdown

This section contains illustrated parts breakdowns for dental lights.

Part Identification Symbols

The conventions for the serviceable components tables are designed to identify all parts and kits, including ones that are not for sale. Symbols with reference notes are used.

Symbol	Definition
†	Indicates that the individual part is not available for sale. (These parts are typically part of a kit or larger assembly that is for sale.)
*	The part belongs to a kit.
No symbol	Part is for sale.

DENTAL LIGHT IPB CONTENTS

- 6300 Light Head, page 46
- Performer Light Head, page 47

6300 Light Head

Part No: 28.1007.00

Item	Part Number	Description
1	28.1004.00	Lamp and holder
2	041.179.01	Lamp
3	75.0084.00	Holder only
4	28.1536.00	Light yoke plug
5	90.0463.01	Lamp socket kit
6	28.1012.00	Shield bracket assembly, package 2
7	28.1001.00	Pivot stop
8	43.0054.00	Intensity switch kit
9	90.1039.00	On/off switch kit
10	28.1464.01	Switch housing kit
11	90.0367.01	Light handle kit
12	002.135.00	Screw

Figure 20 6300 Light Head Components

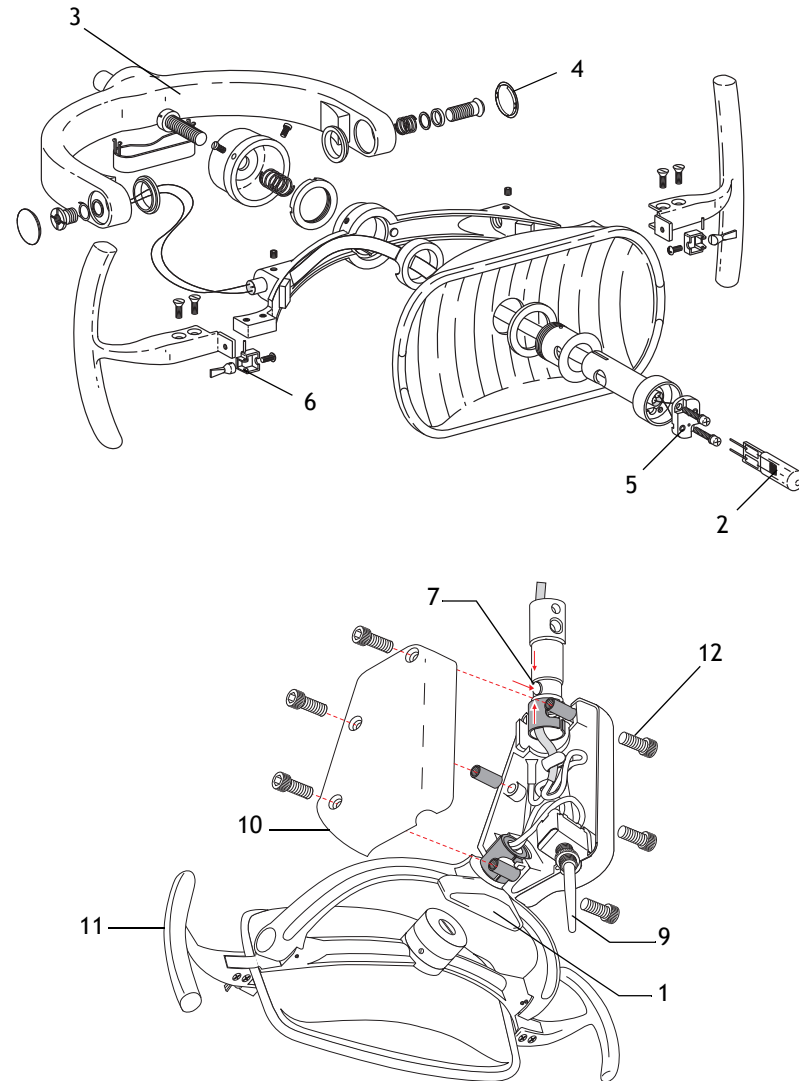

Performer Light Head

Part No: 76.4010.00

Item	Part Number	Description
1	004.207.00	Washer, flat
2	013.100.00	Spring
3	016.054.00	Bearing, thrust
4	28.1172.00	Compression bolt
5	016.053.00	Washer, thrust
6	28.1175.01	Washer, thrust
7	90.1039.00	Toggle switch kit
8	28.1188.00	Handle, On/Off switch
9	28.1289.00	Bulb socket and insulation
10	041.513.00	12 volt, 55 Watt halogen bulb
11	28.1213.00	Bulb cap assembly
12	28.1166.00	Reflector shield

Figure 21 Performer Light Head Components

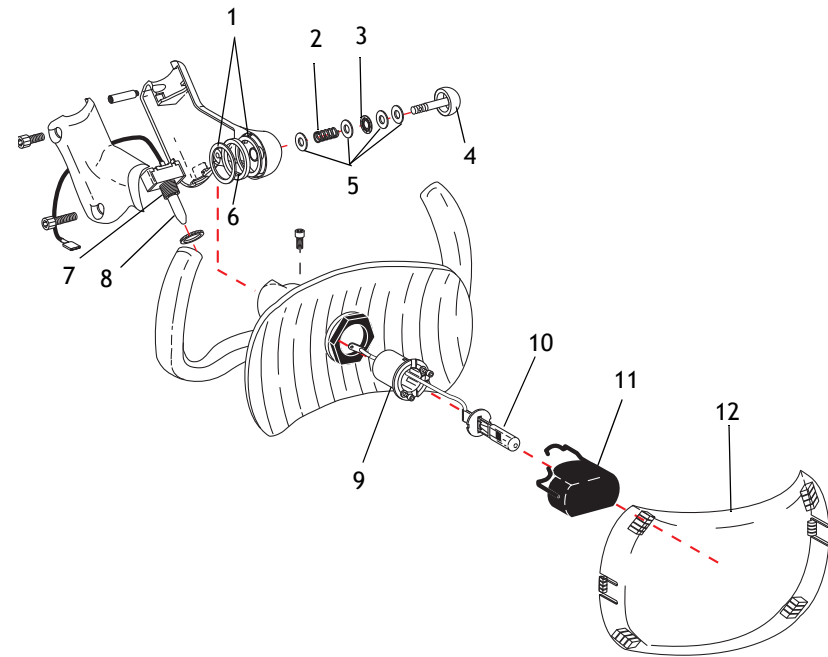

Troubleshooting the Dental Light

Table 16 contains tips and troubleshooting information to assist in diagnosing the most common dental light problems. This table is not intended to cover every situation, but includes the most common problems that you may encounter.

Table 16 Dental Light Troubleshooting

Problem	Possible Cause	Action
Light head is loose or difficult to position	Rotation tension screws are too loose or tight	Adjust the appropriate axis tension
Flexarm drifts	Tension adjustment nut inside the flexarm is too loose or tight	Adjust the flexarm counterbalance
Light intensity is dim, inconsistent, or the color is distorted	Reflector or light shield may be damaged, the intensity switch may be in the wrong position	Follow these steps: <ol style="list-style-type: none"> 1. Clean the reflector and light shield. 2. Check the intensity switch position. 3. Check the line voltage at the wall. 4. Check the light shield for severe abrasions, and replace if necessary. 5. Check the color of the lamp, replace if discolored.
Unsatisfactory light pattern	Light is out of focus, reflector or light shield may be damaged	Follow these steps: <ol style="list-style-type: none"> 1. Focus the light. 2. Check the light shield for severe abrasions, and replace if necessary. 3. Clean the reflector and light shield.
Light does not function	No power to the light, defective socket, lamp has failed, or no power to the transformer	Follow these steps: <ol style="list-style-type: none"> 1. Verify the dental light is connected to a working power source. 2. Ensure all electrical switches are in the On position. 3. Verify the power supply air-electric switch has sufficient air pressure to close. 4. Check for loose connections. 5. Replace the socket, replace the lamp.

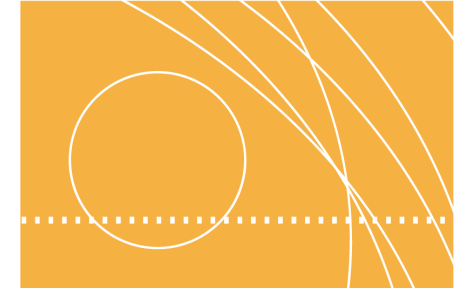

INDEX

Numerics

- 4810, Mobile Simulator, 1, 4, 11
- 4820, Stationary Simulator, 1, 4, 27
- 6300 dental light, 121, 131, 132
 - adjusting focus, 123
 - adjusting the flexarm, 127
 - adjusting the light head, 123
 - adjustments and maintenance, 122
 - cleaning the shield, 128
 - replacing the lamp, 129
 - troubleshooting, 134

a

- A-dec Schools Customer Service, 3
- adjustments
 - 6300 dental light, 123
 - cross-system features, 52
 - Performer dental light, 125
- air filter/regulator, 78
- air vacuum system (AVS)
 - lid, 74

- mobile, 23
- stationary, 34
- troubleshooting, 115
- vacuum generator assembly, 72
- valve assembly, 73
- air-actuated water shutoff, 80
- autoclavable syringe, 70
 - adjustments, 55
 - troubleshooting, 113
- AVS, see *air vacuum system (AVS)*

b

- back and headrest assembly, 86, 87
- bench-mounted utilities, mobile simulator, 20
- brake, torso, 76
 - adjustments, 57
 - troubleshooting, 118
- button valve, 82

c

- carriage assembly



- Century Plus control block, 61
 - standard control block, 60, 61
 - troubleshooting, 98
- casters, 24
- casters, troubleshooting, 120
- Century Plus control block, 63
 - carriage assembly, 61
 - control block manifold, 64
 - handpiece adjustments, 53
 - intraoral light diagram, 48
 - mobile simulator, city water flow diagram, 16
 - mobile simulator, self-contained flow diagram, 15
 - stationary simulator, city water flow diagram, 32
 - stationary simulator, self-contained water flow diagram, 31
 - syringe adjustments, 55
 - troubleshooting, 101
- chair back, 86
 - adjustments, 58
- cleaning, dental light, 128
- Columbia I manikin, 45
- Columbia II manikin, 45
- conventions
 - document, 2
 - formatting, 2
 - part identification symbols, 2, 17, 33, 59, 131
- coolant air adjustment, 54
- coolant water flow adjustment, 54
- cross-system features
 - adjustments and maintenance, 52
 - flow diagrams, 46
 - illustrated parts breakdown, 59
- customer service, 3

- d**
- dental light, 131

- 6300 light, focus adjustments, 123
- 6300 light, lamp replacement, 129
- 6300 light, rotation adjustments, 123
 - adjusting the flexarm, 127
- adjustments and maintenance, 122
- cleaning the shield, 128
- mobile simulator, 5
- Performer light, focus adjustments, 125
- Performer light, lamp replacement, 130
- Performer light, rotation adjustments, 125
- stationary simulator, 6
 - troubleshooting, 134
- drain valve assembly, 74
- drive air pressure adjustment, 54
- dual-voltage intraoral light source adjustment, 56

e

- EA-40LT electrical micromotor, flow diagram, 49
- electrical diagram, power supply and intraoral light, 47, 48

f

- filter/regulator, air, 78
- filter/regulator, water, 78
- flow diagrams
 - cross-system, 46
 - EA-40LT electrical micromotor, 49
 - intraoral light, 47, 48
 - micromotor, 49
 - mobile simulator, 12
 - stationary simulator, 28
- focus, adjusting the 6300 dental light, 123
- focus, adjusting the Performer dental light, 125
- foot control
 - troubleshooting, 110
 - valve assembly, 69



- wet/dry toggle valve, 68
- Frasaco I manikin, 45
- Frasaco II manikin, 45

h

- handpiece adjustments, 53
- handpiece holder arms, 84
- handpiece selector valve
 - three handpiece, 67
 - two handpiece, 66
- handpiece , 44
- headrest adjustment, 58
- headrest assembly, 86, 87
- headrest upholstery, 87
- holder arms, handpiece, 84
- holder, tray, 85
- HVE valve, 71
 - see also *air vacuum system (AVS)*
 - troubleshooting, 114

i

- illustrated parts breakdowns
 - cross-system features, 59
 - dental lights, 131
 - mobile simulator, 17
 - stationary simulator, 33
- inside this guide, 2
- International Customer Service, 3
- intraoral light
 - adjustments, 56
 - Century Plus control block, 48
 - flow diagrams, 46, 47, 48
 - standard control block diagram, 47

k

- Kilgore I manikin, 45
- Kilgore II manikin, 45

l

- lamp replacement
 - 6300 dental light, 129
 - Performer dental light, 130
- lift cylinder, mobile simulator, 24
 - troubleshooting, 120

m

- manifold, Century Plus control block, 64
- manikins, 45
- master toggle, Century Plus control block only, 65
- micromotor, flow diagram, 49
- Mobile Simulator, 1, 4, 11, 17
 - dental light, 5, 121
 - lift cylinder and casters, 24, 120
 - muffler tray, 23
 - utilities, bench mounted, 20
 - utilities, simulator mounted, 18
 - vacuum generator, 23, 72
- Mobile Simulator, flow diagrams, 12
 - city water, Century Plus control block, 16
 - city water, standard control block, 14
 - self-contained water, Century Plus control block, 15
 - self-contained water, standard control block, 13
- model numbers, 4
- monitor mount, stationary simulator, 37

p

- Performer dental light, 121, 131, 133
 - adjusting focus, 125
 - adjusting tension, 125



- adjusting the flexarm, 127
- adjustments and maintenance, 122
- cleaning the shield, 128
- replacing the lamp, 130
- troubleshooting, 134
- plumbing, mobile simulator, 12
- plumbing, stationary simulator, 28
- power supplies
 - 17 Watt, 91
 - 25 Watt, 92
 - 300 Watt, 94
- power supply and intraoral light electrical diagram, 47, 48

r

- replacing the lamp, 6300 dental light, 129
- replacing the lamp, Performer dental light, 130

s

- selector valve
 - three handpiece, 67
 - two handpiece, 66
- serial numbers, 4
- serviceable components, 3
- shutoff valve, air-actuated water shutoff, 80
- Simulator, 1
 - Mobile, Model 4810, 1, 4, 11
 - Stationary, Model 4820, 1, 4, 27
- Standard control block, 62
 - carriage assembly, 60, 61
 - handpiece adjustments, 53
 - intraoral light diagram, 47
 - mobile simulator, city water flow diagram, 14
 - mobile simulator, self-contained water flow diagram, 13
 - stationary simulator, city water flow diagram, 30
 - stationary simulator, self-contained water flow diagram, 29

- syringe adjustments, 55
- troubleshooting, 100
- Stationary Simulator, 1, 4, 27, 33
 - dental light, 6, 121
 - monitor mount, 37
 - vacuum generator, 34, 72
 - writing surface, 36
- Stationary Simulator, flow diagrams, 28
 - city water, Century Plus control block, 32
 - city water, standard control block, 30
 - self-contained water, Century Plus control block, 31
 - self-contained water, standard control block, 29
- support, contact information, 3
- syringe, autoclavable, 70
 - adjustments, 55
 - troubleshooting, 113

t

- tension
 - adjusting the 6300 dental light, 123
 - adjusting the Performer dental light, 125
- third hand kit, 88
- tools, recommended, 8
- torso brake, 76
 - adjustments, 57
 - troubleshooting, 118
- tray holder, 85
- troubleshooting, 97
 - air vacuum system (AVS), 115
 - autoclavable syringe, 113
 - carriage assembly, 98
 - Century Plus control block, 101
 - foot control, 110
 - HVE valve, 114
 - mobile lift cylinders and casters, 120



- standard control block, 100
- torso brake, 118

- cross-section, 44
- handpiece, 44
- overview, 41

U

- upholstery, headrest, 87
- utilities, mobile simulator, bench mounted, 20
- utilities, mobile simulator, simulator mounted, 18

V

- vacuum canister assembly, 74
- vacuum generator, 72
 - mobile simulator, 23
 - stationary simulator, 34
- troubleshooting, 115

W

- water filter/regulator, 78
- wet/dry toggle valve, 68
- writing surface, stationary simulator, 36



Regulatory Information

Regulatory information mandated by agency requirements is provided in the *Regulatory Information, Specifications, and Warranty* document (p/n 86.0221.00), which is available in the Document Library at www.a-dec.com.

A-dec Simulators Service Guide



A-dec Headquarters

2601 Crestview Drive
Newberg, Oregon 97132
United States
Tel: 1.800.547.1883 within USA/CAN
Tel: +1.503.538.7478 outside USA/CAN
Fax: 1.503.538.0276
www.a-dec.com

A-dec Australia

Unit 8
5-9 Ricketty Street
Mascot, NSW 2020
Australia
Tel: 1.800.225.010 within AUS
Tel: +61.(0).2.8332.4000 outside AUS

A-dec China

A-dec (Hangzhou) Dental Equipment Co., Ltd.
528 Shunfeng Road
Qianjiang Economic Development Zone
Hangzhou 311106
Zhejiang, China
Tel: +1.503.538.7478

A-dec United Kingdom

Austin House, 11 Liberty Way Nuneaton,
Warwickshire CV11 6RZ England
Tel: 0800.ADEC.UK (2332.85) within UK
Tel: +44.(0).24.7635.0901 outside UK

85.0814.00 Rev E
Copyright 2015 A-dec Inc.
All rights reserved.