



A-DEC INC.
2601 CRESTVIEW DRIVE
POST OFFICE BOX 111
NEWBERG, OREGON 97132 USA
TELEPHONE (503)-538-9471

A-DEC DENTAL U.K., LTD.
AUSTIN HOUSE
11 LIBERTY WAY
ATTLEBOROUGH FIELDS INDUSTRIAL ESTATE
NUNEATON, WARWICKSHIRE
ENGLAND CV116RZ
PHONE: 0800-ADECUK (233285) WITHIN UK 00
44 24 7635 0901 OUTSIDE UK

A-DEC AUSTRALIA
41-43 BOWDEN STREET
ALEXANDRIA, N.S.W. 2015
AUSTRALIA
TELEPHONE (61) 1.800.225010

CHECK WITH LOCAL CODE AUTHORITIES ABOUT INSTALLATION REQUIREMENTS FOR THIS PRODUCT

INSTALLATION INSTRUCTIONS

PERFORMER[®] ASSISTANT'S ARM TO PERFORMER III CHAIR

BEFORE BEGINNING THIS INSTALL

1. Remove the chair seat upholstery if installed.
2. Lower the chair back to nearly full down so that the gap in the link arm aligns with the mounting hole.

TOUCH PAD FOOTSWITCH

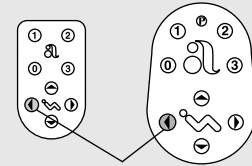

CHAIR BACK DOWN

YOU WILL NEED:

- Hex keys: 3/32", 5/32", 5/16"

HARDWARE INCLUDED:

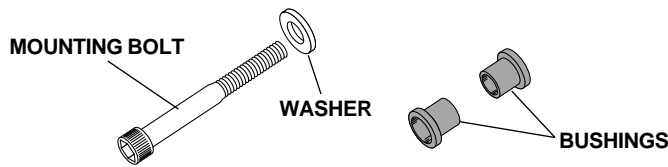

ASSISTANT'S ARM MOUNTING HARDWARE

INSTALL THE ASSISTANT'S ARM

1. Remove and discard the rubber band which holds the mounting hardware in the assistant's arm. Remove the mounting bolt and washer.
2. While holding the bushings in place, align the assistant's arm with the chair mounting hole.
3. Insert the mounting bolt through the chair mounting hole and assistant's arm.
4. Tighten the bolt firmly into the chair base casting. Check that the arm rotates easily but does not drift or sag; tighten the bolt further if necessary.

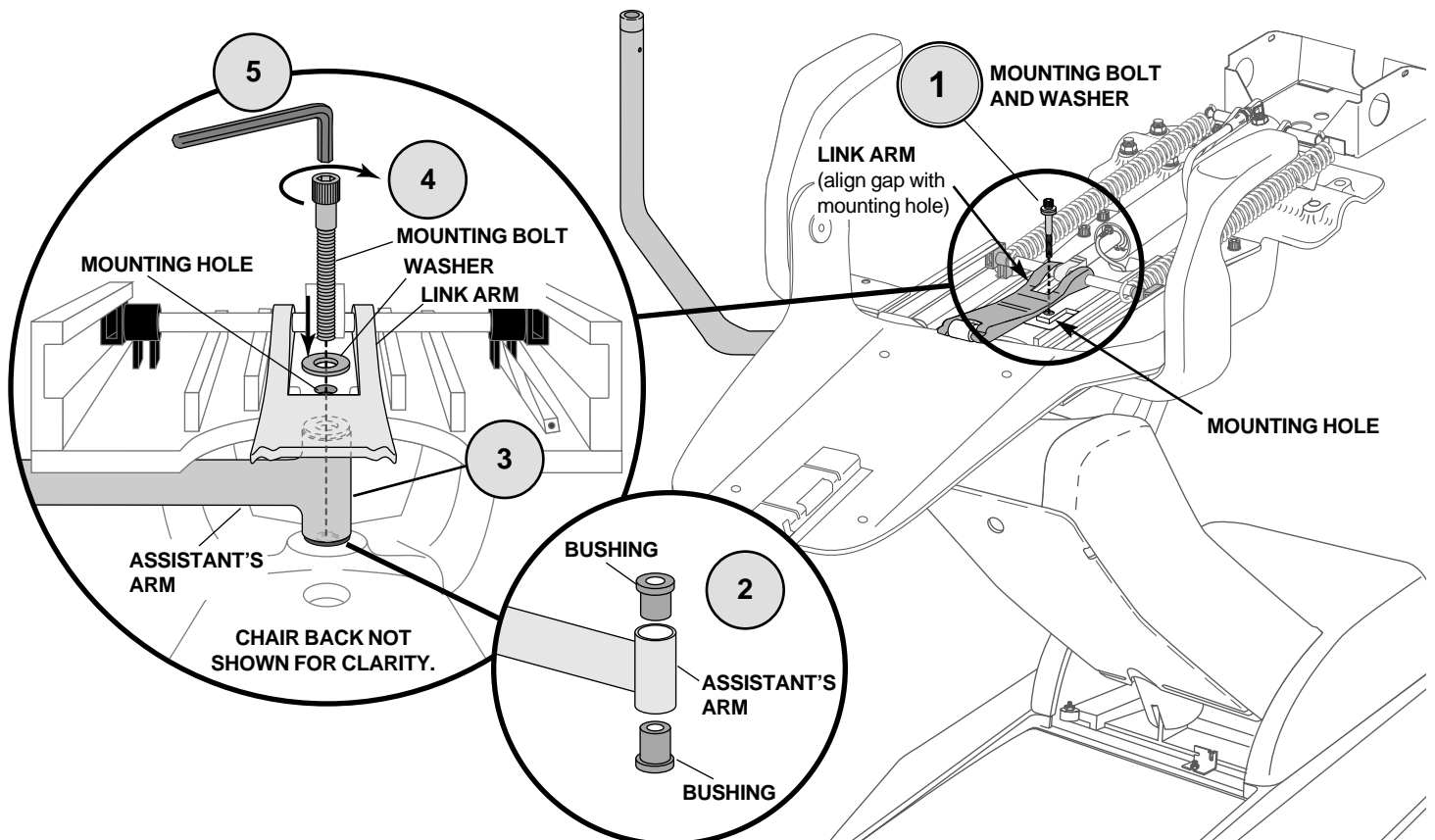

REMOVE THE ASSISTANT'S HOLDER

Refer to the appropriate instructions for removing the assistant's holder.

CUSPIDOR:

1. Remove and set aside the cup fill spout, bowl rinse spout, and bowl screen.
2. Lift the upper cuspidor housing off the lower cuspidor housing.
3. Loosen the two screws in the underside of the cuspidor housing.
4. Lift the holder clamp.
5. Remove the holder from the cuspidor housing.
6. Re-tighten the screws.
7. Install the hole plug into the empty assistant's holder hole.

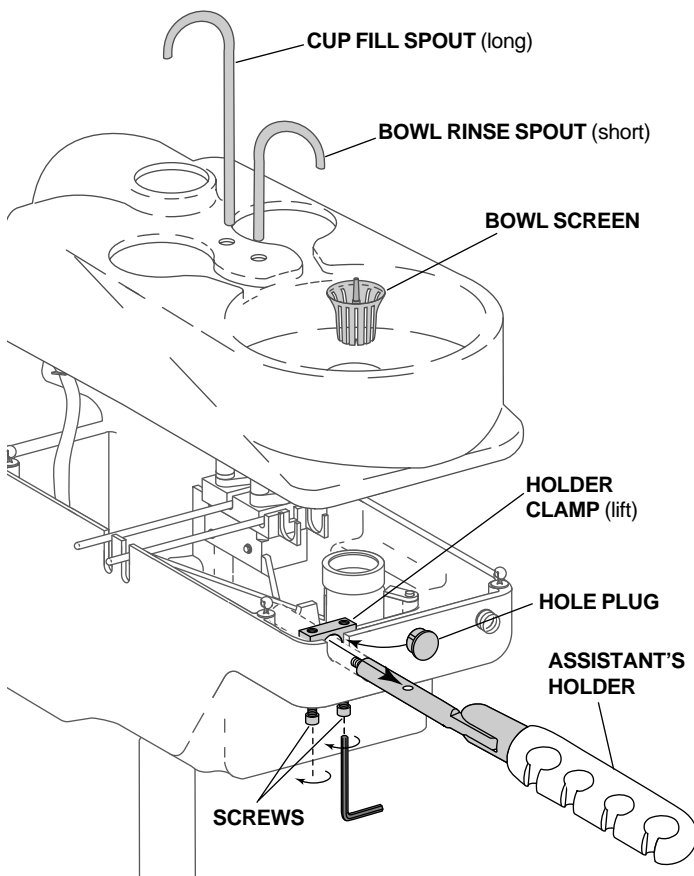

REMOVE THE ASSISTANT'S HOLDER FROM THE CUSPIDOR

8. Place the upper cuspidor housing onto the lower cuspidor housing.
9. Reinstall the cup fill spout, bowl rinse spout and bowl screen to the cuspidor.

ASSISTANT'S INSTRUMENTATION:

1. Pull off the assistant's instrumentation cover.
2. Using a hex key, loosen the setscrew that holds the assistant's holder in place, then remove the holder.
3. Insert the plug into the empty assistant's holder hole.
4. Reinstall the cover.

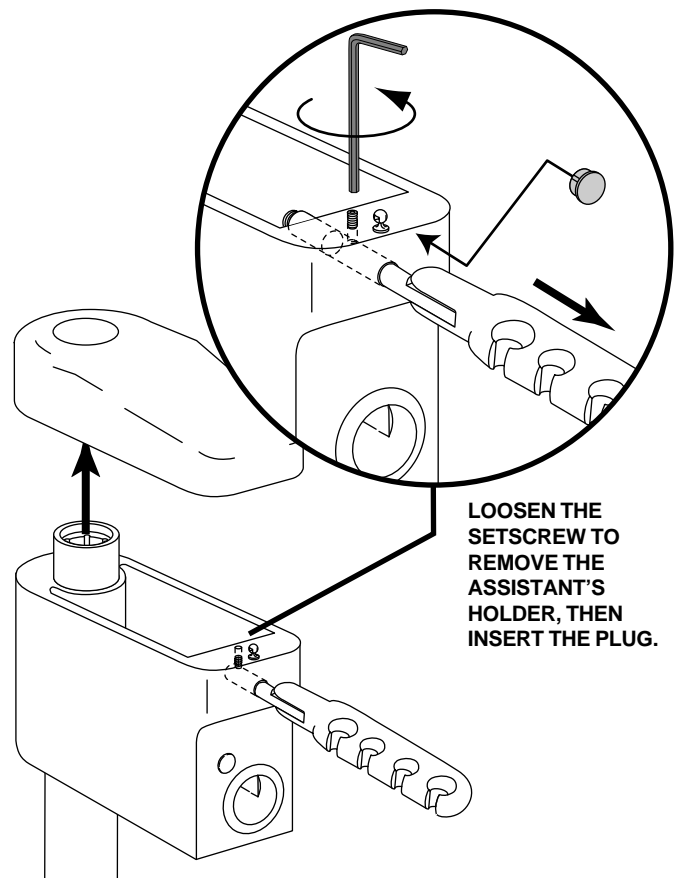

REMOVE THE ASSISTANT'S HOLDER FROM THE ASSISTANT'S INSTRUMENTATION

REMOVE THE ASSISTANT'S HOLDER

Refer to the appropriate instructions for installing the assistant's holder.

STANDARD ASSISTANT'S HOLDER:

1. Rotate the assistant's holder, then insert it into the assistant's arm and tighten the tension adjustment setscrew.
2. Place the assistant's instrumentation in the assistant's holder.

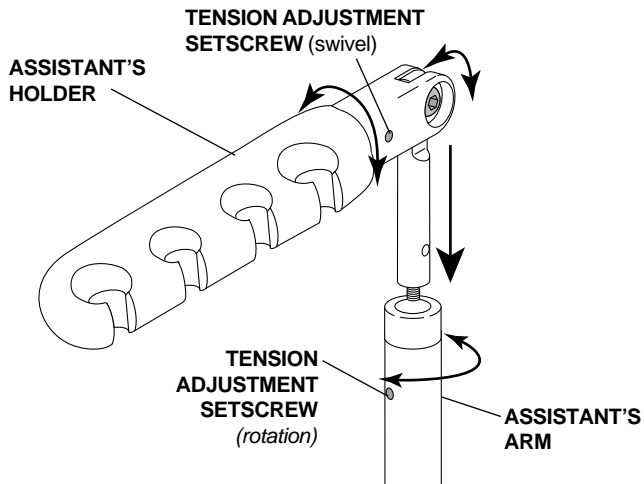

INSTALL THE ASSISTANT'S HOLDER

AUTO-ELECTRIC ASSISTANT'S HOLDER (INTERNATIONAL SINGLE-OPERATOR CUSPIDOR ONLY):

1. Remove the adapter bar from the auto-electric holder bar.

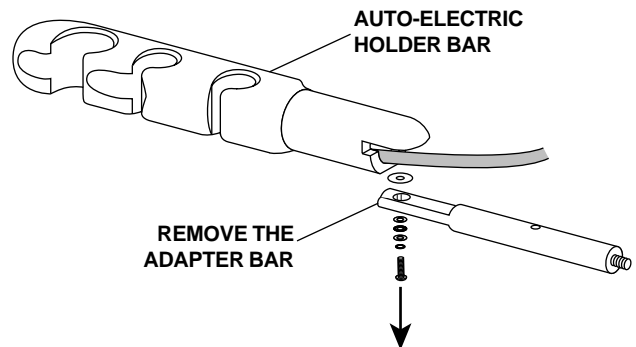

REMOVE THE ADAPTER BAR

2. Install the threaded end of the adapter bar firmly into the holder bar (use a hex key for assistance), then insert it into the assistant's arm and tighten the tension adjustment setscrew.
3. Place the assistant's instrumentation in the assistant's holder.

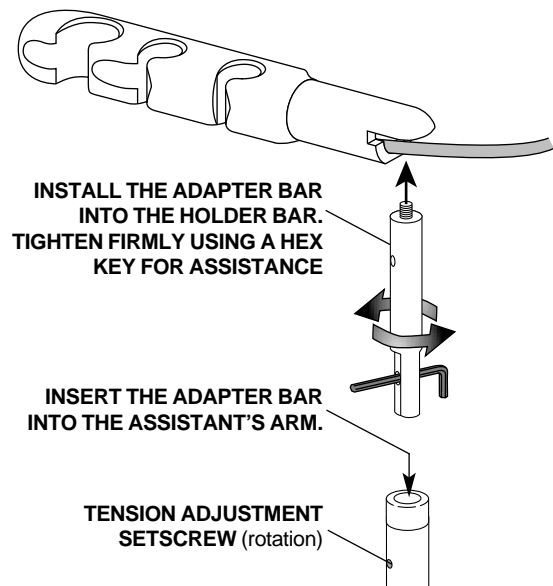

INSTALL THE AUTO-ELECTRIC ASSISTANT'S HOLDER

BEFORE LEAVING THE FACILITY

1. Adjust the arm and holder tension by tightening or loosening the mounting bolt and setscrew tension adjustments.
2. Install the chair seat upholstery.
3. Return the chair to the entry/exit position (chair back up/chair base down).



Recycle
Conserve

Made with 10% post-consumer fiber